



ADVANCED DESIGN MANUAL











© 2010



Design Tools

General

Select
Pan
Zoom Reset
Zoom In
Zoom Into
Caliper
Rotate
Delete
Zoom Out
Zoom Out of

Icon		Description
Select		Clicking Select allows you to select an object on the Drawing Board. Objects turn red when they are selected. To select more than one object, press the shift key while you select each object.
Pan		Click Pan, then drag an item across the drawing board to pan from side to side.
Zoom Reset		Returns you to the view you previously had when the drawing board was first opened.
Zoom In		This enlarges the visual display of the selected item.
Zoom Into		Zooms into the currently selected Light, Face, and Point.
Caliper		The calipers cursor is positioned on the drawing board where you want the X and Y axis to be situated. The cursor's distance from the x-axis, distance from the y-axis and distance from the axis point (i.e. 0,0) is shown at the bottom of the dialog box. On the frame drawing board, the calipers allow you to define and measure distances between objects.
Rotate		Rotates the frame to the orientation you want.
Delete		Deletes the item you have selected on the drawing board.
Zoom Out		This reduces the visual display of the selected item.
Zoom Out of		Zooms out of the current view.

Design Tools

Section 1 - Wireframe Tab

Merge Lite
Lock / Unlock Points

Section 2 - Resources Tab

Nested Frames
Assembly Substitution
Reverse Assembly
Merge Assemblies
Lights Equal on Height
Add Frame View

Section 3 - Joints Tab

Section 4 - Tools Tab

Thumbnail
Refresh

Section 5 - Wizards Tab

Options Wizard
Assembly Wizard
Grid Frame Wizard
Stepped Frame Wizard
Split Light Wizard
Horizontal Dimension Wizard
Vertical Dimension Wizard

Section 6 - Macro Tab -

Can consist of some or all of these depending on the framing system.

Door Macro
Height & Width Macro
Lite By Lite Glazing Macro
Sub-Head & Sub-Sill Macro
Angle Macro
Raked Frame
Curved Frame
Nested Frame



Design Tools

Section 1 - Wireframe Tab

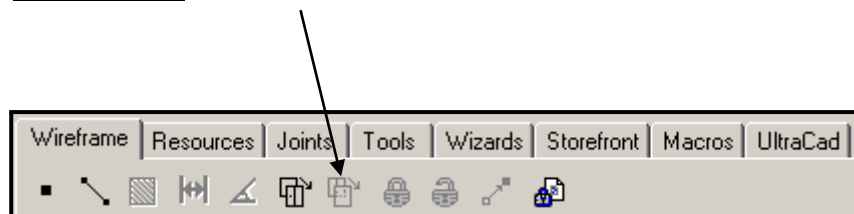
Merge Light



If you require to Merge Lights this can be achieved by the following steps -

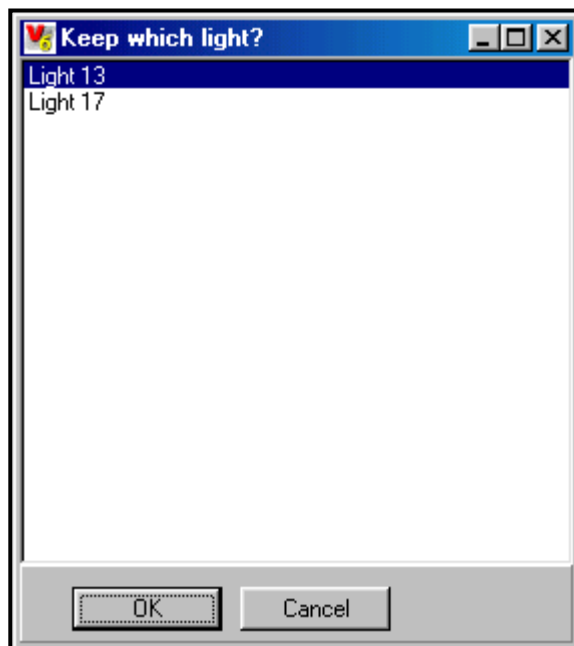

- You need to be in the Zoomed in View on your Drawing Board. Click on the frame so it is highlighted red, then click on the  button.
- Select the Lights that you want to merge by either selecting them on the drawing board or under the Objects Tree. (Remembering that if you want to select more than one light to hold the Shift Key on your Keyboard).
- Click on the Wireframe Tab and click on the  button.
- This will display the following box asking you which light you would like to keep.

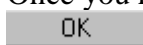

- Once you have selected the Light you would like to keep then click on the  button. This will then Merge the Lights.

Unlock and Lock Points

When you are creating a Frame (eg; light code 22) by default the Points are locked, so when you move Points and Lines these will move as one. To unlock points-

- You need to be in the Zoomed in View on your Drawing Board. Click on the frame so it is highlighted red, then click on the  button.
- Drag your mouse over the Lines and Points that you want to Unlock so these are highlighted red. (See the following picture).
- Then click on the  button to Unlock the points. Or to lock the points click on the  button.
- In this example the whole transom could be moved up and down by clicking either side transom and moving it. If you wished to move the transoms separately you will need to Unlock the Lines and Points of the transom and jambs.

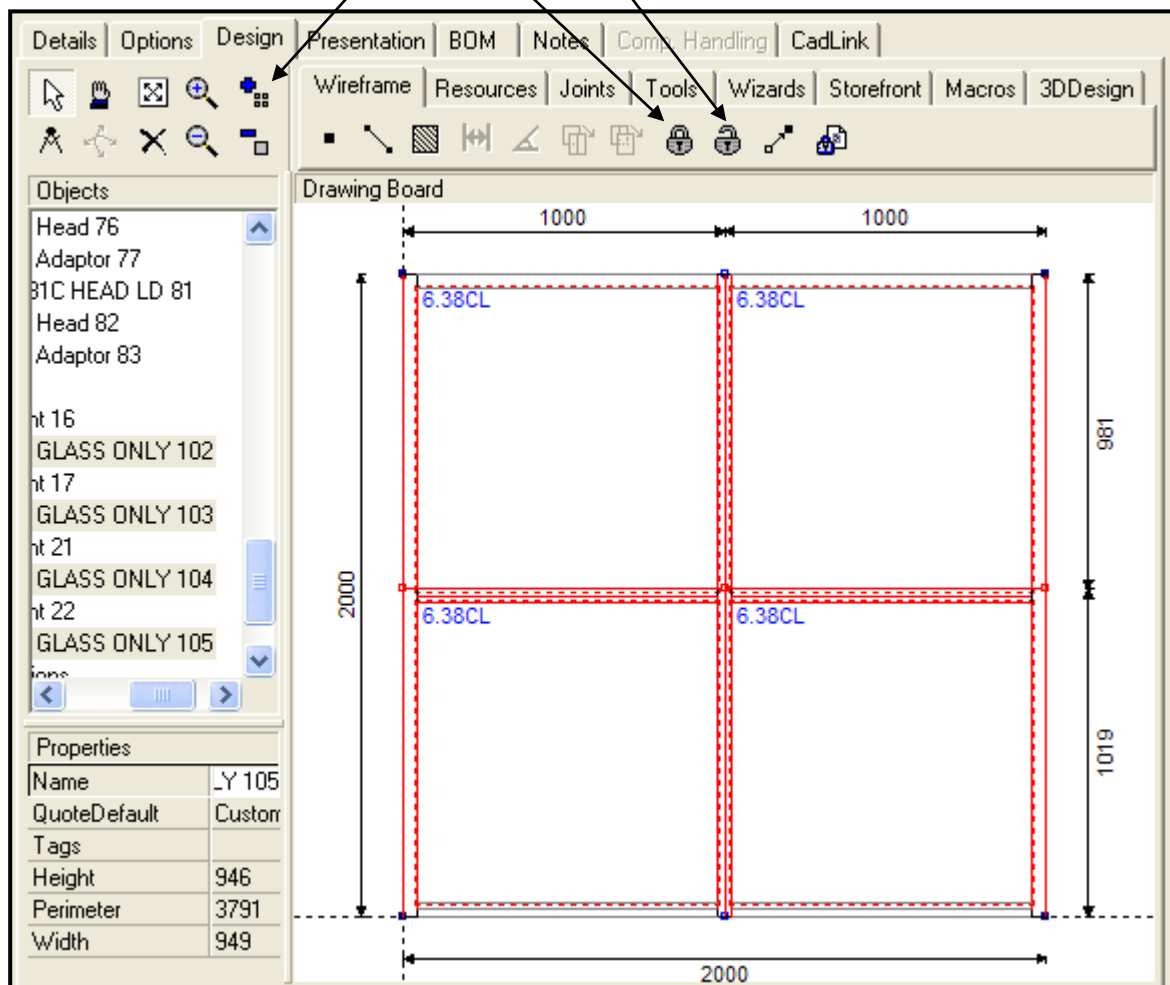

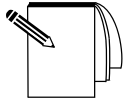
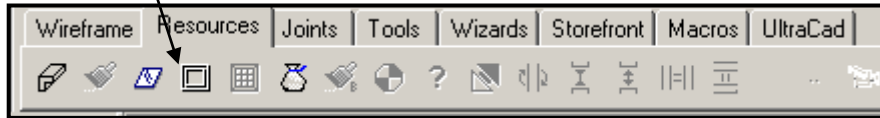

Section 2 - Resources Tab

Nested Frame



Note: The Nested Frame Macro on the Macro tab should be used instead as this eliminates the possibility of placing a nested frame into an incorrect receptor. Refer Section 6 of this manual.

To Nest Glass use following steps -

- You need to be in the Zoomed in View on your Drawing Board. Click on the frame so it is highlighted red, then click on the  button.
- Select the Light so it is Highlighted red. Click on the Resources Tab and click on the following icon .
- This will display a Frame Picker Browser, from here you are can only select to place glass into the lite.
- Select from the list then click on the  button.
- This will then display a “Place in Receptor?” box, like the following.

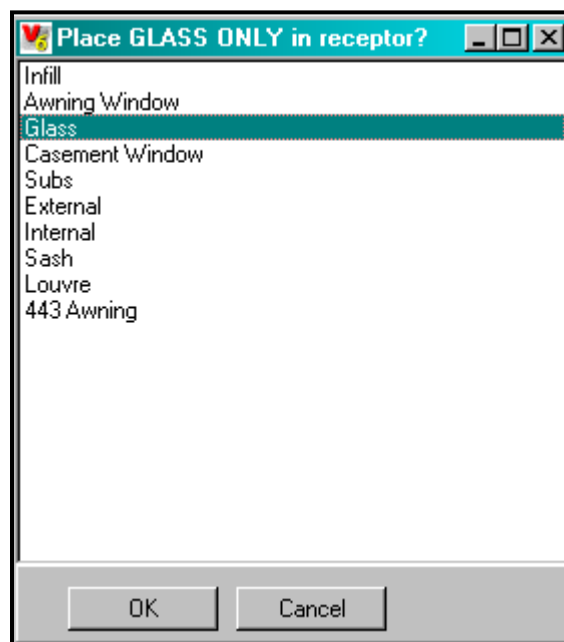

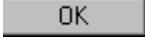
- Select the Glass Receptor and click the  button.

Assembly Substitution

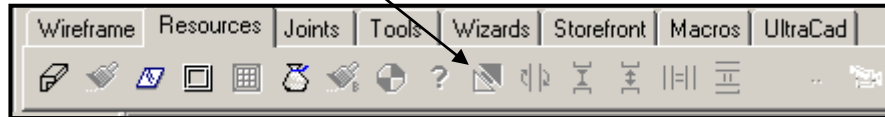

If you require a different Assembly to the one that you first selected you are able to use the Substitution icon.

- Select the Assembly which you want to Substitute, by selecting it in the Objects Tree.
- Click on the Resources Tab and click on the  button.
- This will bring up an Assembly Picker Box, select the Assembly you require and click on the button.
- This will then Substitute the Assembly for the one that you have selected.

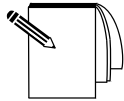

Note: If the Assembly that you have selected does not substitute make sure to check that your joints have remained.

Reverse Assembly

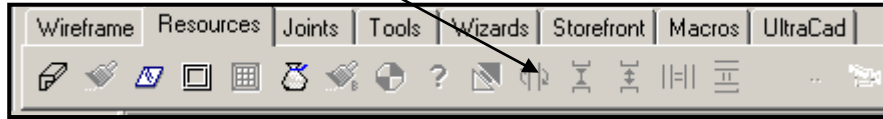

Once you have placed an Assembly onto your frame and if you notice that the Extrusion you require is on the wrong side you can select Reverse Assembly. This will reverse the Assembly.

- Select the Assembly that you want to Reverse, by selecting it in the Objects Tree.
- Click on the resources tab then click on the following icon , this will reverse the Assembly.

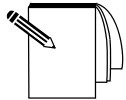

Note: This should not need to be used as the database has been designed to orientate the assemblies the correct way around.

Merge Assemblies



This is used after placing assemblies across 2 or more lites via the assembly wizard. (Refer page 20)

If you require to Merge Assemblies this is achieved by the following –

- Select the Assemblies by selecting them in the Objects Tree, remembering to Hold Shift on your Keyboard to select more than one.
- Click on the Resources Tab and then click on the  button.
- This will then merge the Assemblies.

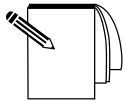

Note: Make sure that your points have been locked. After merging you will need to fix the joints – Refer Section 3 – Joints tab.

Example – Merging two AS106 sub sills.

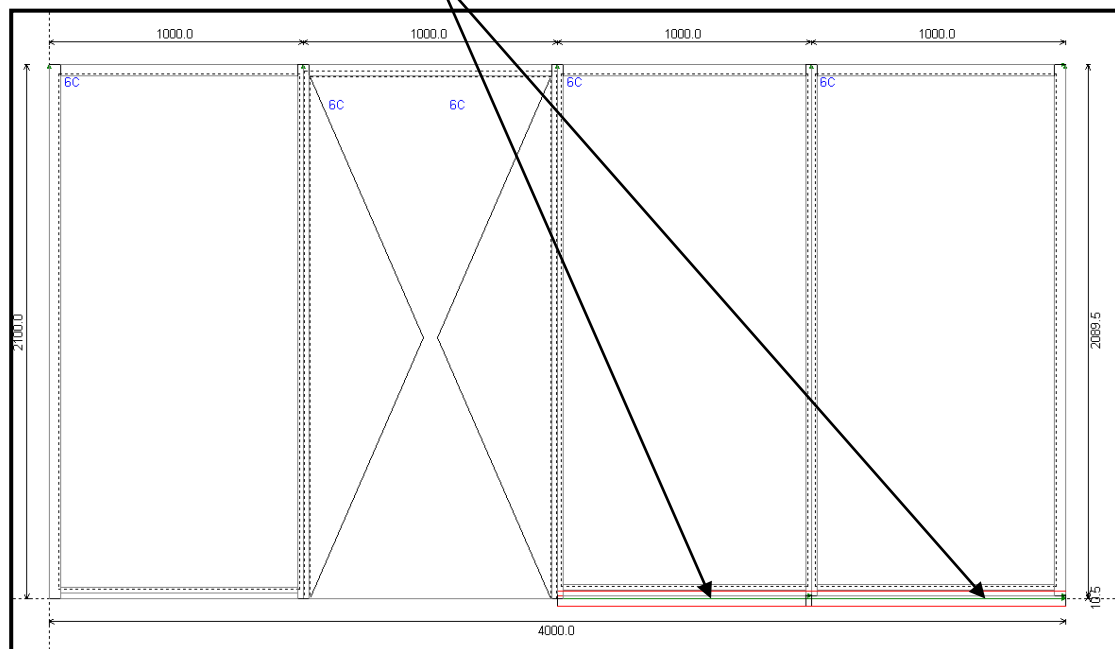

Lights Equal on Width

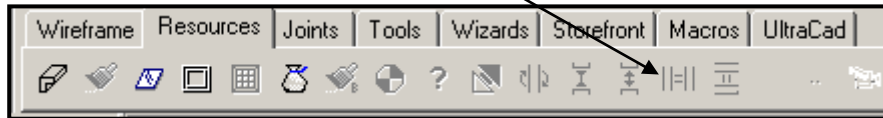

If you require to make the Lights Equal on Width this is achieved by the following –

- Select the Lights that you want to make equal, by clicking and selecting them on your drawing board, remembering to hold the Shift Key on your keyboard to select more than one.
- Click on the Resources Tab and then click on the  button.
- This will then display the following box, asking you to select which Receptor to use.

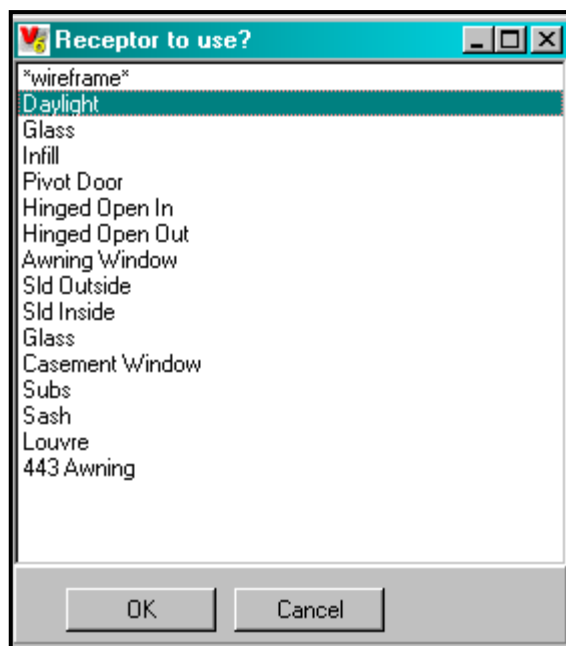

- Select the Receptor and press the OK Button.

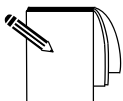

Note: To Achieve equal Glass and Equal Heads and Sills use the Glass or Daylight Receptor.

Lights Equal on Height

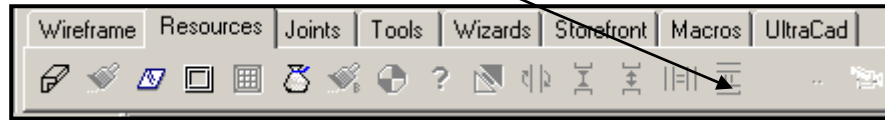

If you require to make the Lights Equal on Height this is achieved by the following –

- Select the Lights that you want to make equal, by clicking and selecting them on your drawing board, remembering to hold the Shift Key on your keyboard to select more than one.
- Click on the Resources Tab and then click on the  button.
- This will then display the following box, asking you to select which Receptor to use.

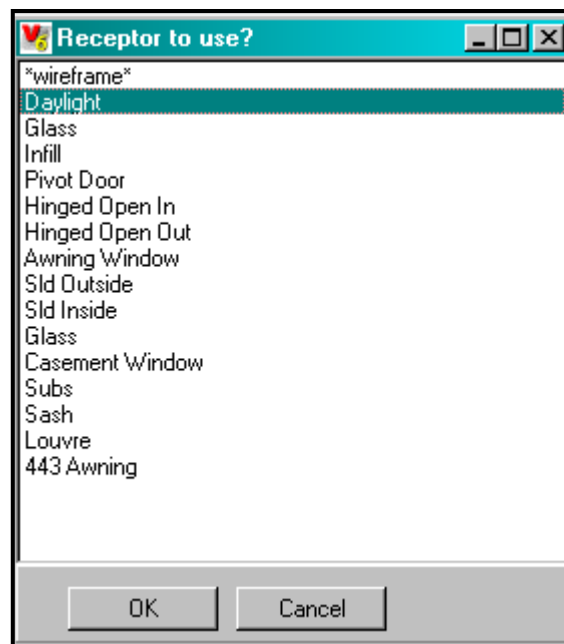

- Select the Receptor and press the OK Button.

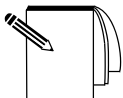

Note: To Achieve equal Glass use the Glass or Daylight Receptor.

Add Frame View



Frame View is denoted by a graphic of a video camera.  You must be in **Frame View** to use this function.

Frame View allows the estimator to capture of snap-shot of the frame at any angle or view they wish. Simply generate the view or rotation you wish and press the  button. This Frame view taken is added to the Objects tree from where it can be viewed at any time.

To view a previously saved Frame View –

1. Select the View from the Object tree
- 2) Right-click and select EDIT

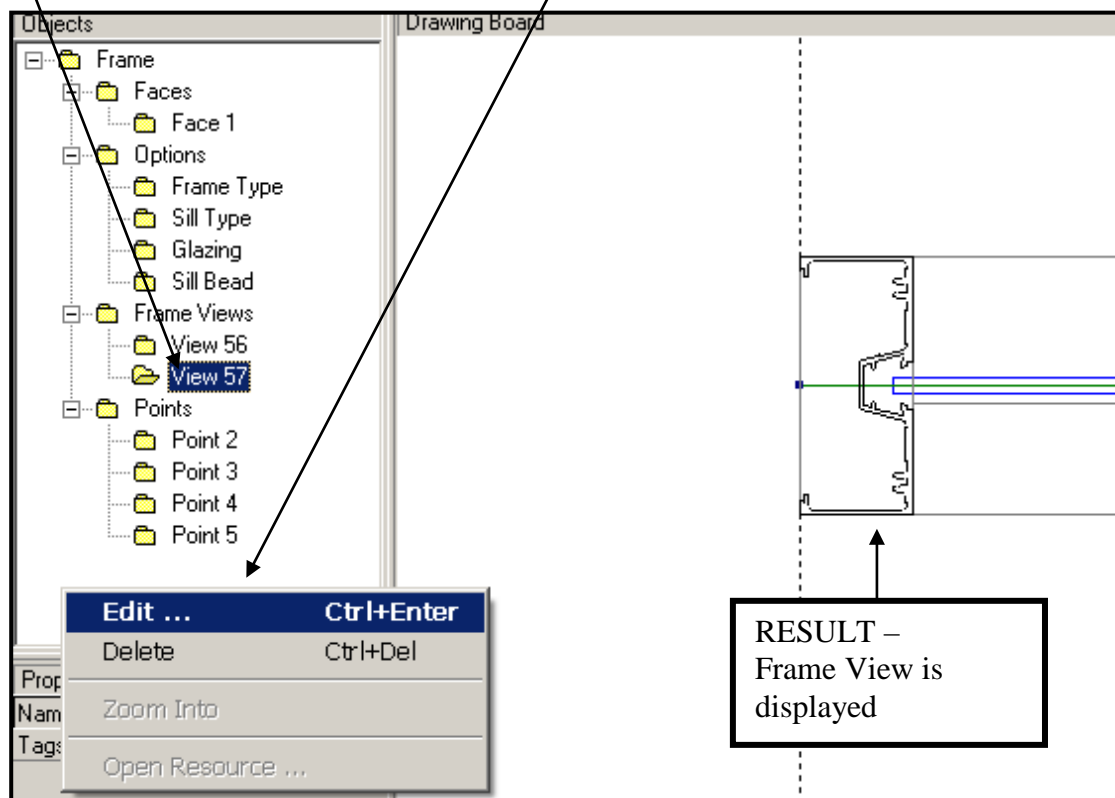

Note: to view the Frame Views in the Objects Tree select Zoom out of mode 



Frame View snap-shots are also available for use within the Presentation tab.

Section 3 - Joints Tab



This function is generally taken care of automatically when the grid frame wizard is run but can be useful if a joint is not correct.

Instructions below explain how to correct a cut.

- Click on the Joints tab.
- Click on the Frame so it is highlighted Red. Click on the  button, to zoom into the Frame. (If you are not already zoomed in).
- Make sure you have your Points Displayed on the Drawing Board. Right Click and go to Display. Make sure the Points has a check next to it.
- Select one of the Points on the outer Frame. This can be done by either clicking on the point on the Drawing Board or selecting it in the Objects tree on the left hand side.
- Click on the  button and this will zoom into the point you have selected. This will then look like the following.

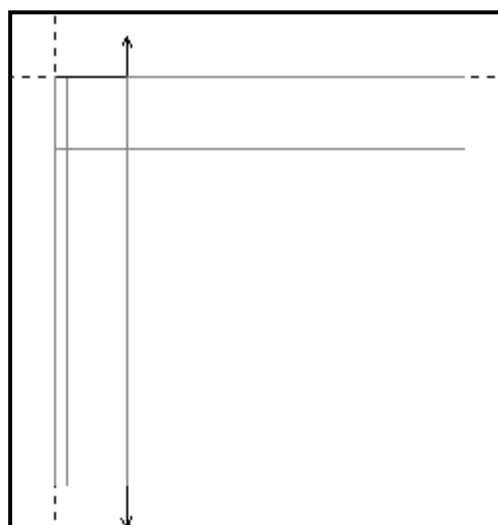

Joints Tab (Continued)

- You now need to select the Extrusion and the Buttline you would like to join. This is done by holding the Shift Key on your Keyboard and selecting the two from the Objects Tree on the Left hand side. See the following picture.

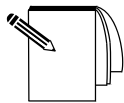
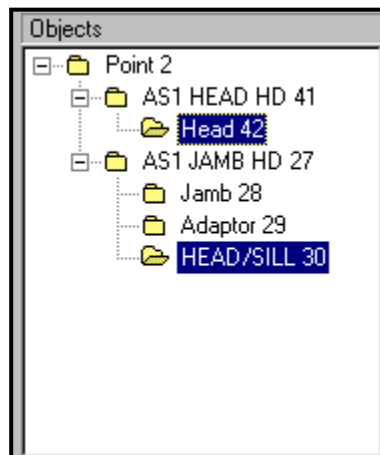

Note: All the Butt Lines are in Upper Case and all the Extrusion names are in Proper Case.

- The drawing board will then look like the following.

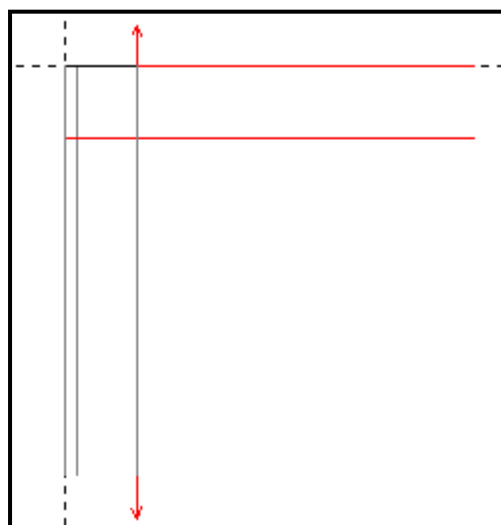

Joints Tab (Continued)

- You will notice that our Head Extrusion has been selected and our HEAD/SILL Buttline has been selected. We can now join the two.
- Click on the  button and this will join the two. Your Drawing Board should now look like the following.

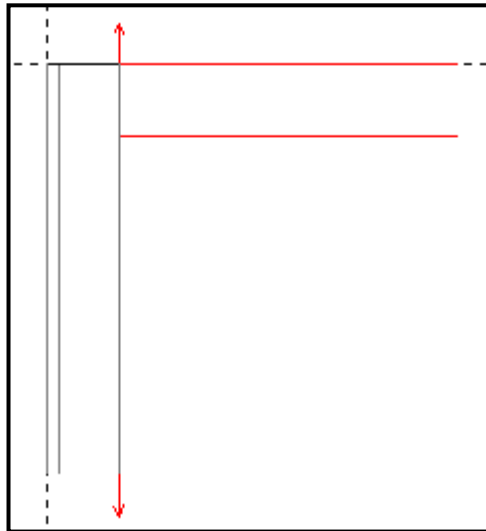

- You will notice that the two have joined. You will need to repeat these steps for all of the Points that you would like to join.

Section 4 - Tools Tab

Thumbnail

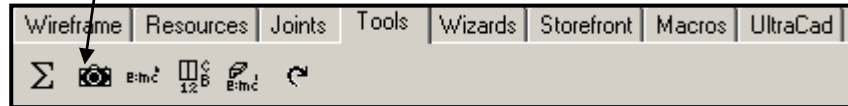

When you create a Frame in the Design View you are able to take what's called a Thumbnail. This is a picture of your frame that you have created. This picture will then be placed on your reports. The Thumbnail can be taken either when you are Zoomed Into the Frame or Zoomed out of the Frame.

You may want certain things not to be displayed when you take a Thumbnail such as the Points for a neater appearing picture. To do this Right Click on the Drawing Board and click on Display. The following menu appears.

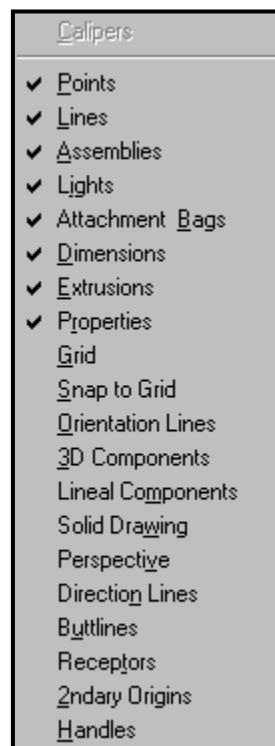

From this menu you can select or de-select what you require or don't require.

Click on the Tools tab and then click on the  button. You will notice that a Thumbnail now appears on the bottom Left Hand corner of the quote of that particular item.

Refresh

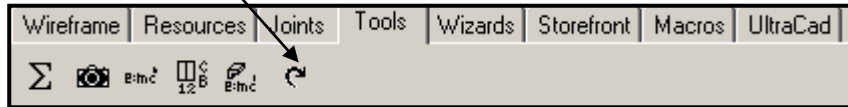

To Refresh the view within the Design Tab click on the Tools tab and click on the , this will refresh the view.

Section 5 - Wizards Tab

Options Wizard

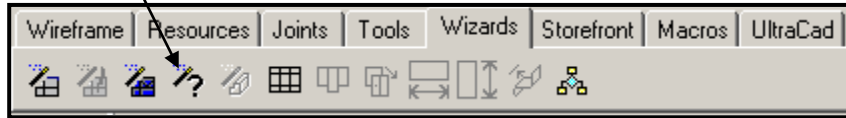

Here you are able to select Finishes, Glass and change Frame Options.

- Click on the Wizards Tab then click on the  button. This will display the following screen.

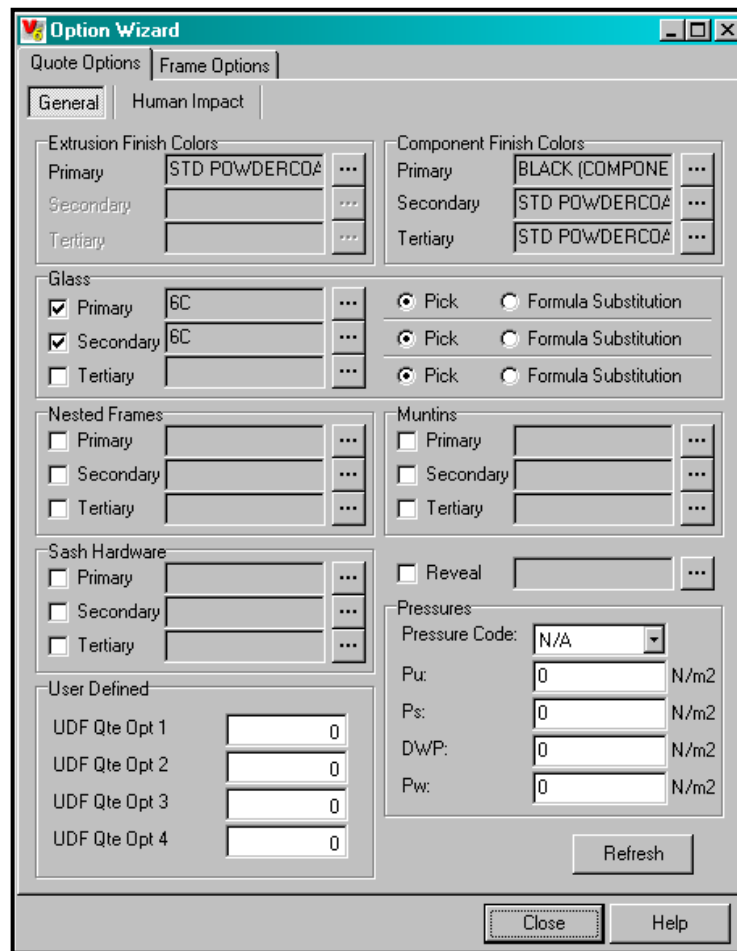

You will notice that this is the same screen that is displayed from within the Defaults Tab within the quote and also the Items/Options Tab, Edit Options.

- By clicking on the  will bring up a picker box for you to select either Finish or Glass. (View next page)

Options Wizard (Continued)

From within this screen you are also able to change frame options.

- Click on the Frame Options Tab. Here it lists all the available options for that frame.
- Clicking next to a frame option will bring down a drop down menu allowing you to select from the choices listed. This can also be done from within Items/Options Tab.

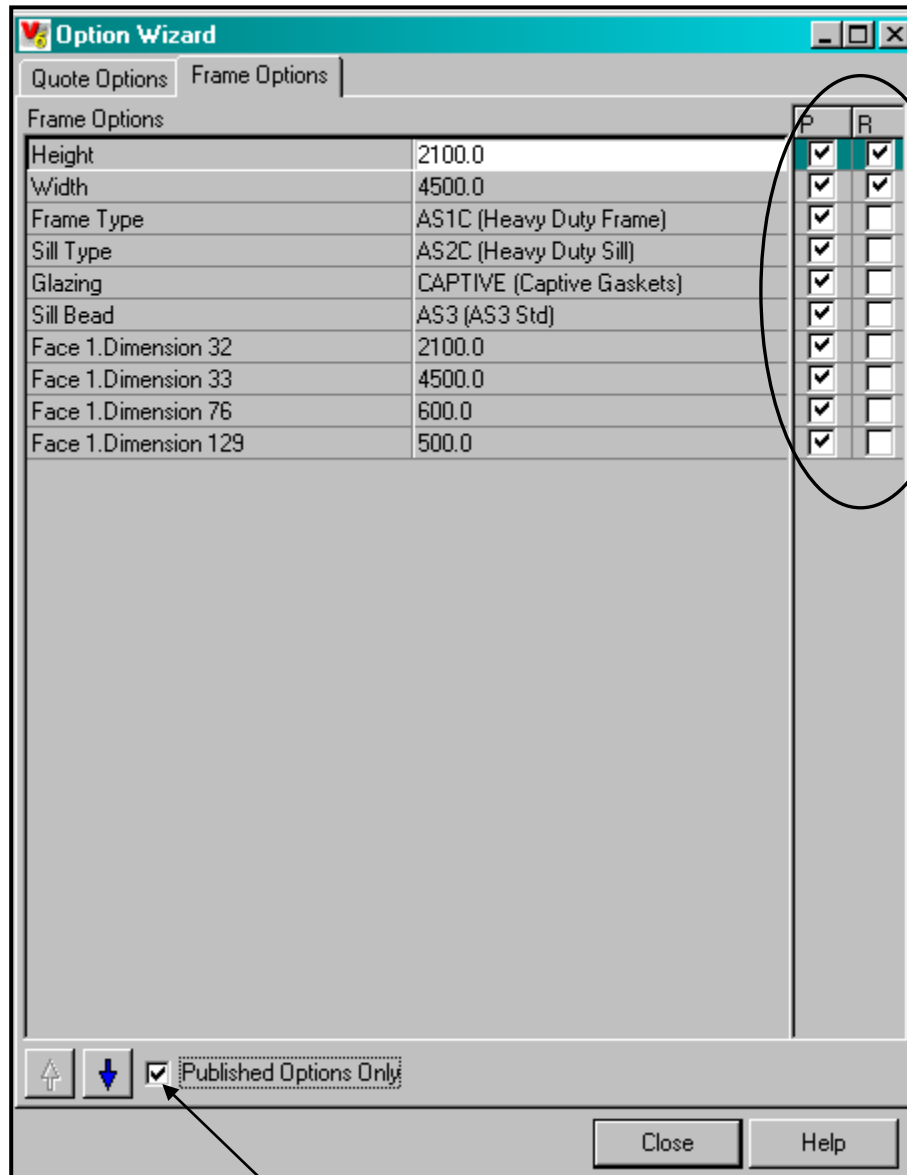



IMPORTANT
Do Not check or uncheck these boxes.

- A tick in this box will show only the options you can select.

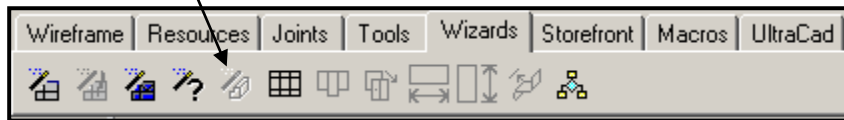
Assembly Wizard



If you require an Assembly to be placed within a Light or Lights this can be done by the following steps –

- Click on the Frame so it is highlighted Red. Click on the  button, to zoom into the Frame.
- Select the Light or Lights which the Assembly is to be placed on.
- Click on the Wizards Tab and then click on the  button.
- This will display the following box.

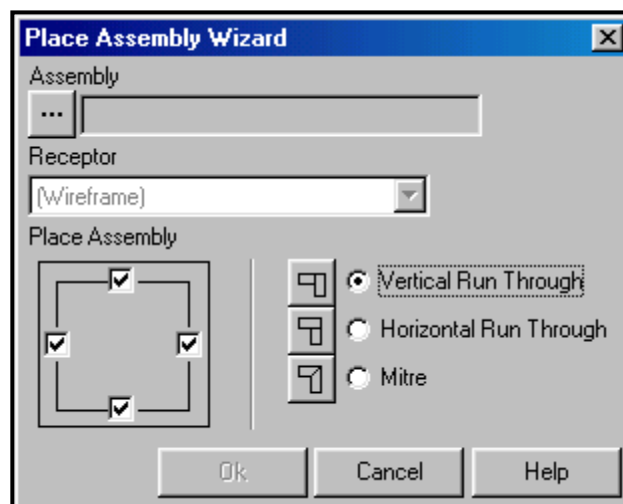

- Select where you want to place the Assembly by de-selecting the Check Boxes and only leaving the one where you want to place the Assembly. Eg. For a Sill it should look like the following.

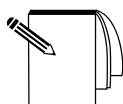



Note: This wizard is required when placing sub sills only partly across the sill of a frame (2 or more lites next to a door). After inserting the assembly you will need to use the Merge Assembly wizard to ensure the sub sill is one continuous length. (Refer page 9)

It is also useful when placing horizontal beads in the Hastings Suite when the mullions are structurally glazed.

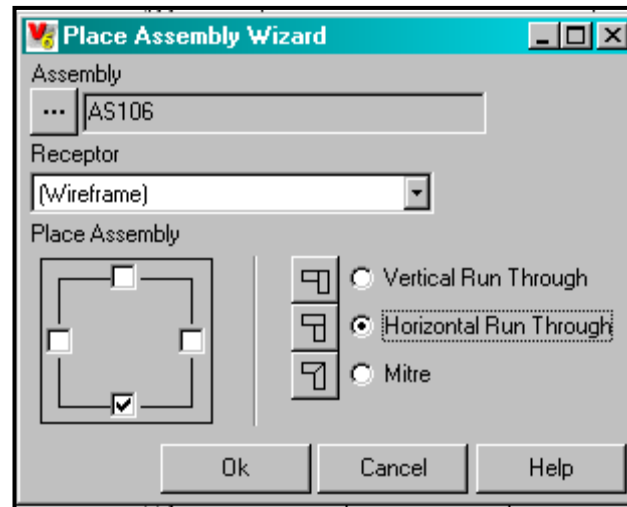
Assembly Wizard (Continued)



- You are now able to select your Assembly by clicking on the  this will then display an Assembly Picker Box, select from the List and then click on the  button.
- You will need to select the Receptor that you want to place this on. Click on the dropdown arrow and select the Receptor.
- Once you have selected click on the  button and this will place the Assembly onto your Wireframe.
- You will need to make sure that your Joints are correct.

Grid Frame Wizard

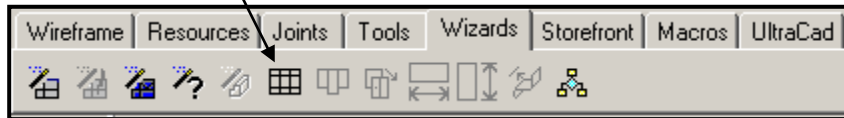

Each Frame Group within the ALSPEC database has a **DESIGN frame**.

IT IS STRONGLY ADVISED that you use this **DESIGN frame** whenever a special shape/style is required.

Once you have added your Design Frame (by adding a standard existing frame) to the Quote it is now time to create the frame using the **Grid Frame Wizard**. The Grid Frame Wizard allows you to create a complete frame.

- Click on the Design Tab from within the Quote - Select the Wizards Tab and Click on the following icon , this will then display the following screen.

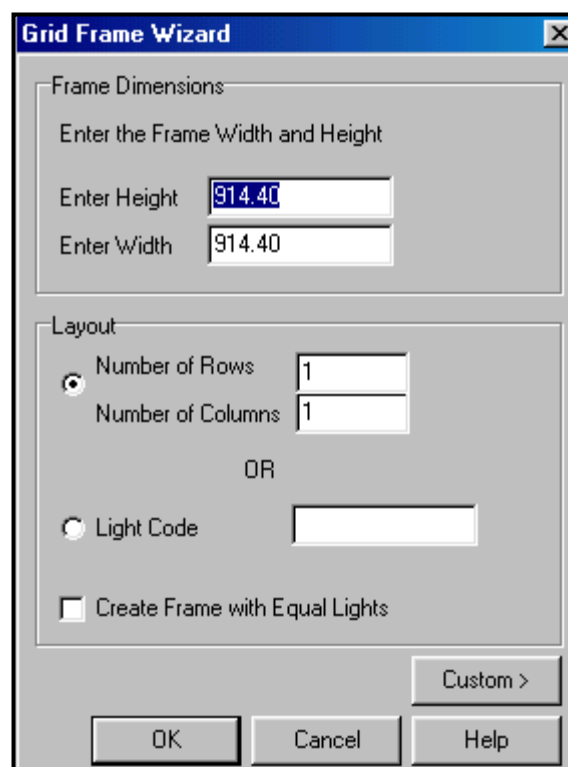
A screenshot of the 'Grid Frame Wizard' dialog box. It has a title bar with 'Grid Frame Wizard' and a close button. The dialog is divided into two sections: 'Frame Dimensions' and 'Layout'. In the 'Frame Dimensions' section, there are two text input fields: 'Enter Height' with the value '914.40' and 'Enter Width' with the value '914.40'. In the 'Layout' section, there are two radio buttons: 'Number of Rows' (selected) and 'Number of Columns' (unselected), each with a text input field containing '1'. Below these is the text 'OR', followed by a radio button for 'Light Code' with an empty text input field. At the bottom of the 'Layout' section is a checkbox for 'Create Frame with Equal Lights'. At the bottom of the dialog are three buttons: 'OK', 'Cancel', and 'Help'. A 'Custom >' button is located to the right of the 'OK' button.

Enter the Frame Height & Width

Enter in the Height and Width of the frame. (Millimetres)

Layout

Enter in the Number of Rows (i.e. Horizontals) and/or enter in the Number of Columns (i.e. Verticals).

Light Code

If the number of rows is to be different for each column, enter a light code in this field. Entering a light code (instead of columns and rows) can create frames that have a different number of lights in each column. Eg. A light Code of 213 will draw the following Wire Frame. ie. 2 Lights, 1 Light, 3 Lights.

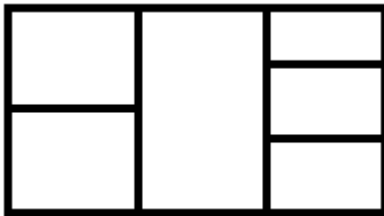

Create Frame with Equal Lights

Check this box to create equal lights.

- Clicking on the Custom button will present the following screen.

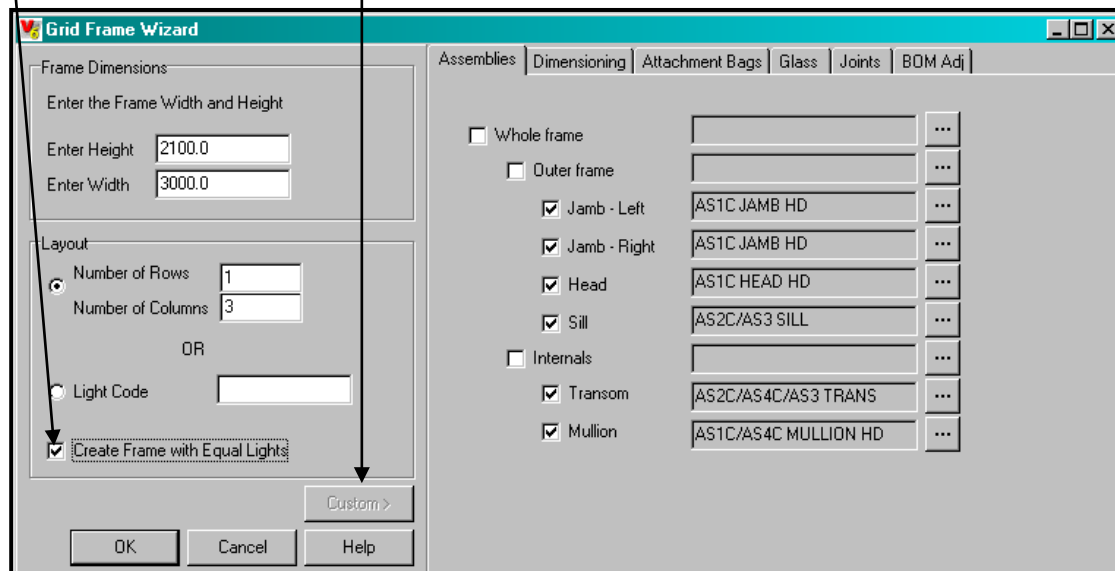

Assemblies Tab

This tab allows you to select the Assemblies that are going to be placed onto your Wireframe. These will be set to defaults but you are able to select others by clicking on the  Button will bring up an Assembly Browser.

Select from the list then click the  button. Repeat this step until you have placed Assemblies on all of the Lines.

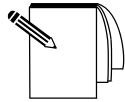

Note: For internal lines such as Transom and Mullions if you have selected more than one, these can be selected here and then Substituted at a later stage. Please see steps that follow.

Glass Tab

This tab allows you to select the Glass that you require for the Frame. This can also be done on the Items/Options Tab, Edit Options.

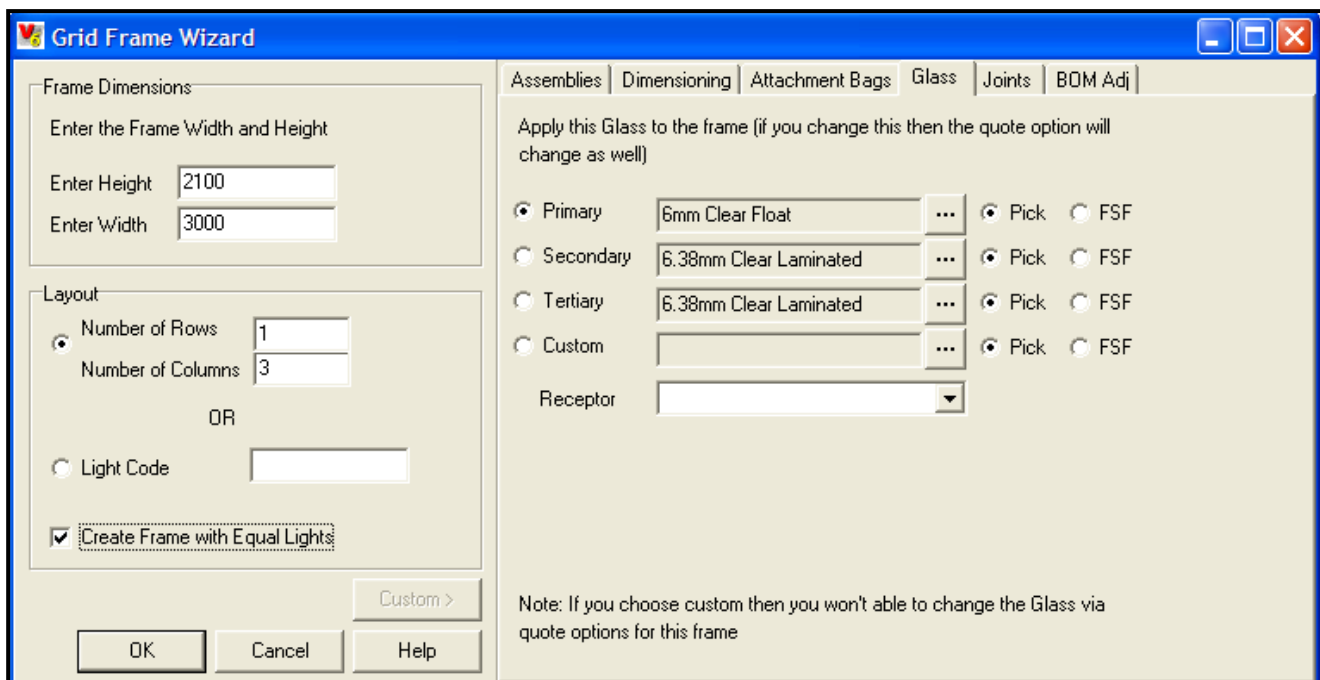

The screenshot shows the 'Grid Frame Wizard' dialog box with the 'Glass' tab selected. The dialog is divided into several sections:

- Frame Dimensions:** Contains input fields for 'Enter Height' (2100) and 'Enter Width' (3000).
- Layout:** Contains radio buttons for 'Number of Rows' (1) and 'Number of Columns' (3), an 'OR' separator, a 'Light Code' field, and a checked checkbox for 'Create Frame with Equal Lights'.
- Assemblies | Dimensioning | Attachment Bags | Glass | Joints | BOM Adj:** This is the active tab. It contains a note: 'Apply this Glass to the frame (if you change this then the quote option will change as well)'. Below this are four radio button options:
 - Primary:** 6mm Clear Float, with 'Pick' selected and 'FSF' unselected.
 - Secondary:** 6.38mm Clear Laminated, with 'Pick' selected and 'FSF' unselected.
 - Tertiary:** 6.38mm Clear Laminated, with 'Pick' selected and 'FSF' unselected.
 - Custom:** (empty field), with 'Pick' selected and 'FSF' unselected.
- Receptor:** A dropdown menu.
- Note:** 'Note: If you choose custom then you won't able to change the Glass via quote options for this frame'.
- Buttons:** 'OK', 'Cancel', 'Help', and 'Custom >'.

Joins Tab

This tab allows you to set the joints for the Outer Framing. The default joints are the following.

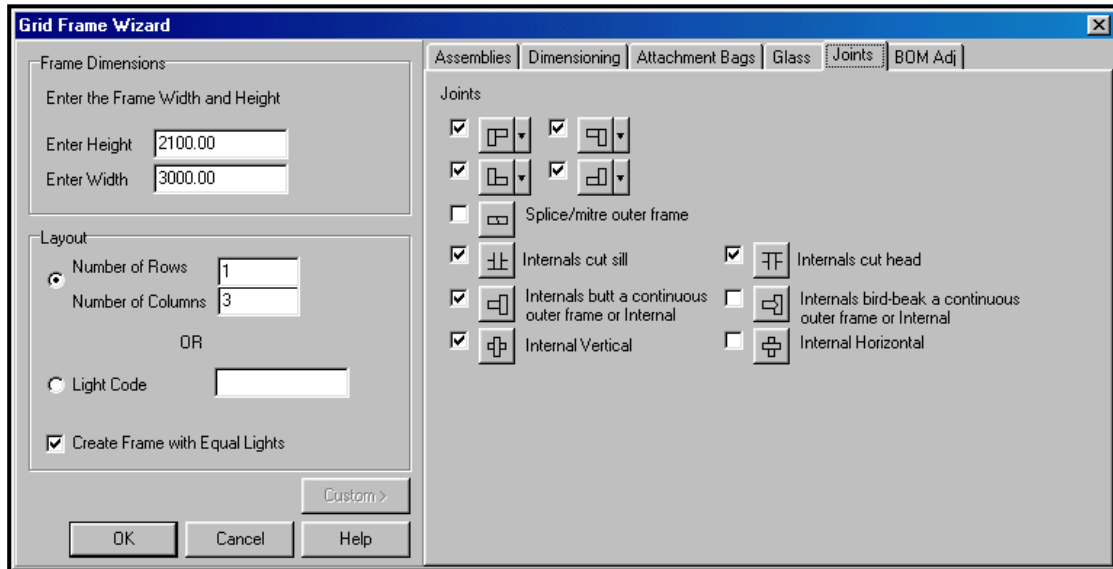

Joins have been set to a Default of the above. For both Outer Framing and Internal Cuts.

By clicking on the arrow will produce the following drop down menu, allowing you to select what Assembly will run through or which one will cut on the outer points of the frame. However these shouldn't need to be changed from what they are.

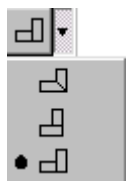

This represents the Head and Sill are cut between the Jambs.

Click on the  button once you have finished this will then populate your Wireframe.

Joints Tab (Continued)

Your drawing board should now look like the following –

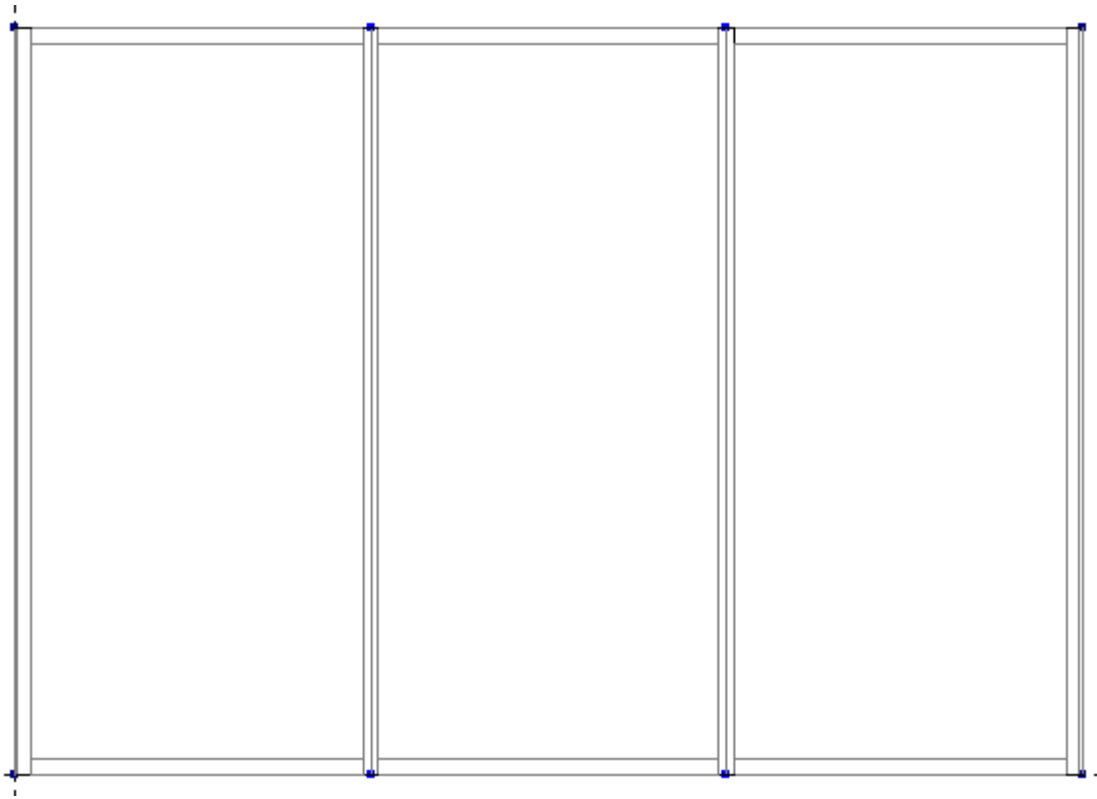

Stepped Frame Wizard

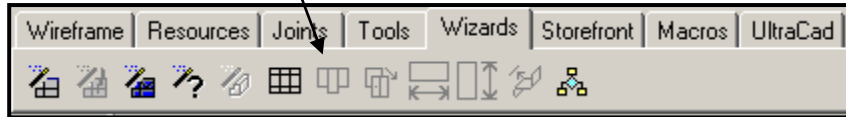

To create a frame with a stepped sill in V6, you must first create a rectangular frame with all assemblies and fills, then remove a portion of the frame. The Stepped Frame Wizard performs the removal.

The Wizard will need a Head or Sill Assembly to be selected in order to complete the operation. It will remove all the Assemblies on the Head, Sill, left and right Jamb surrounding the Light, and split any up if necessary. The first internal horizontal assembly found will be substituted for the new head or sill assembly.

A step will be created where at least two lights exist, one of top of the other. In the case where only one light exist the entire light including head/sill and fill will be removed.

V6 will automatically shorten vertical Assemblies – such as Jambs and Mullions, and will remove Lights and Fills, and place sill assemblies along the new edge and reconstruct all joints during the process.

If you require to Step a Frame this is achieved by the following steps –

- Click on the Frame so it is highlighted Red. Click on the  button, to zoom into the Frame.
- Click on the Light so it is highlighted Red.

Eg. Your frame will look something like the following –

Stepped Frame Wizard (Continued)

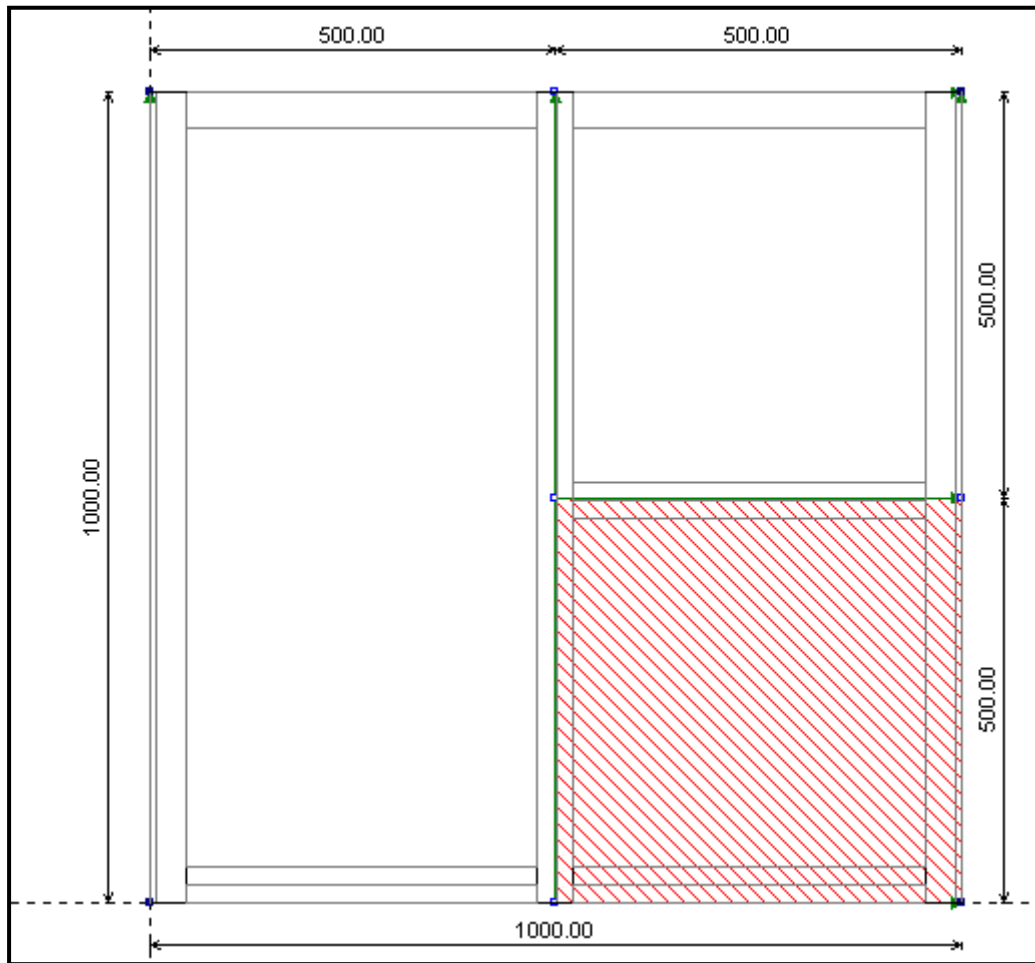

- Click on the Wizards Tab and click on the  button. This will display the following box –

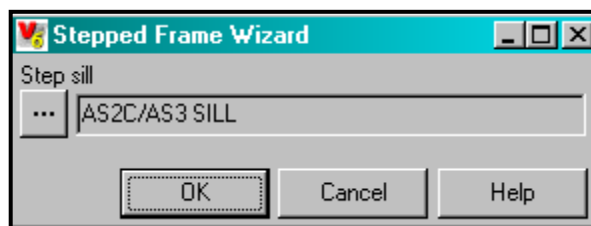

- Click .

Stepped Frame Wizard (Continued)

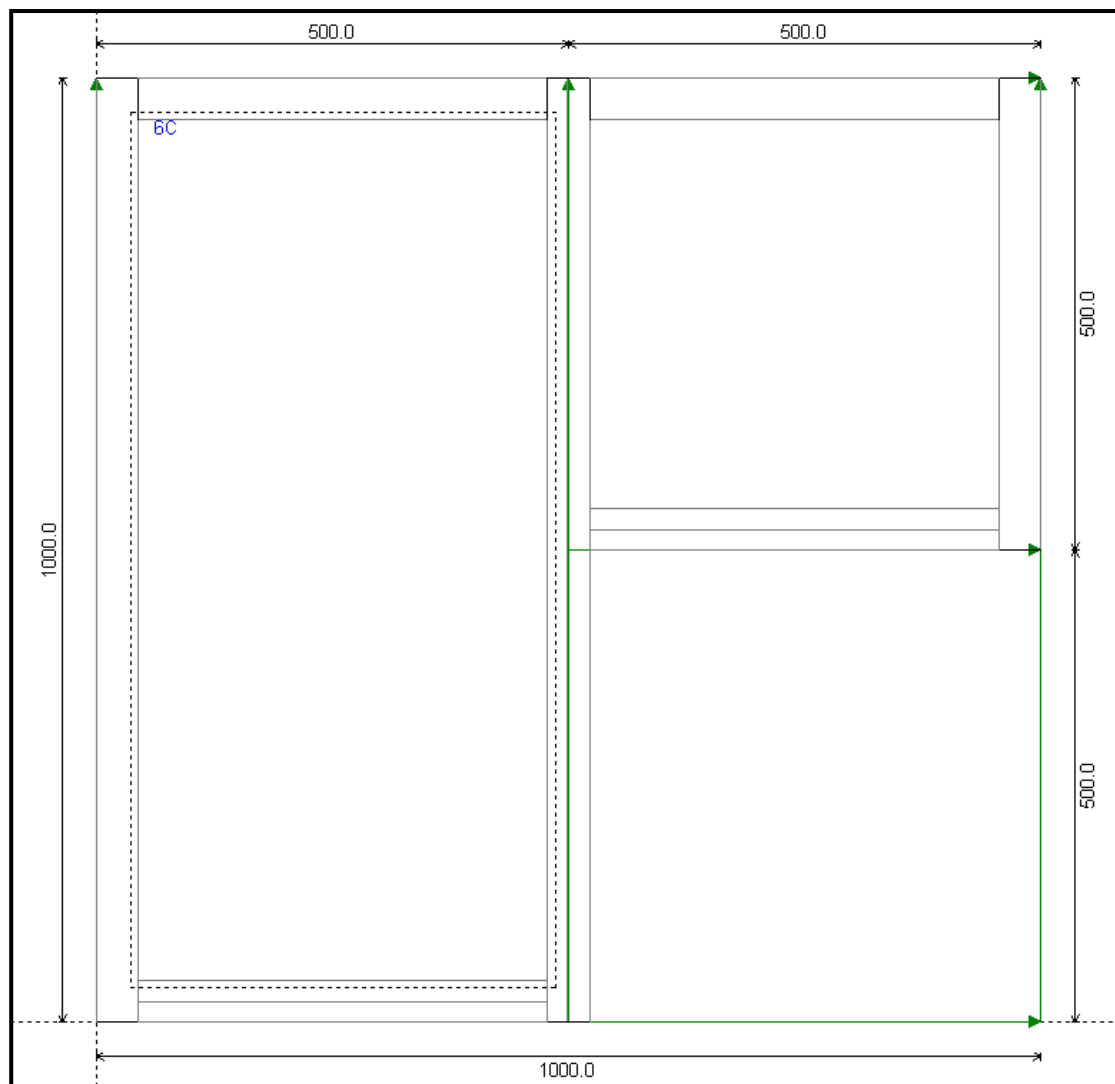

- Your drawing board will then look like the following –

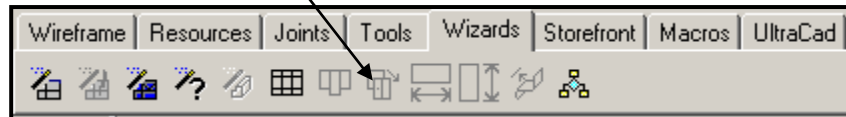

Split Light Wizard



If you require to Split the Lights this is achieved by the following steps –

- Click on the Frame so it is highlighted Red. Click on the  button, to zoom into the Frame.
- Select the Light or Lights that you want to Split.
- Click on the Wizards Tab and click on the  button.
- This will then display the following box.

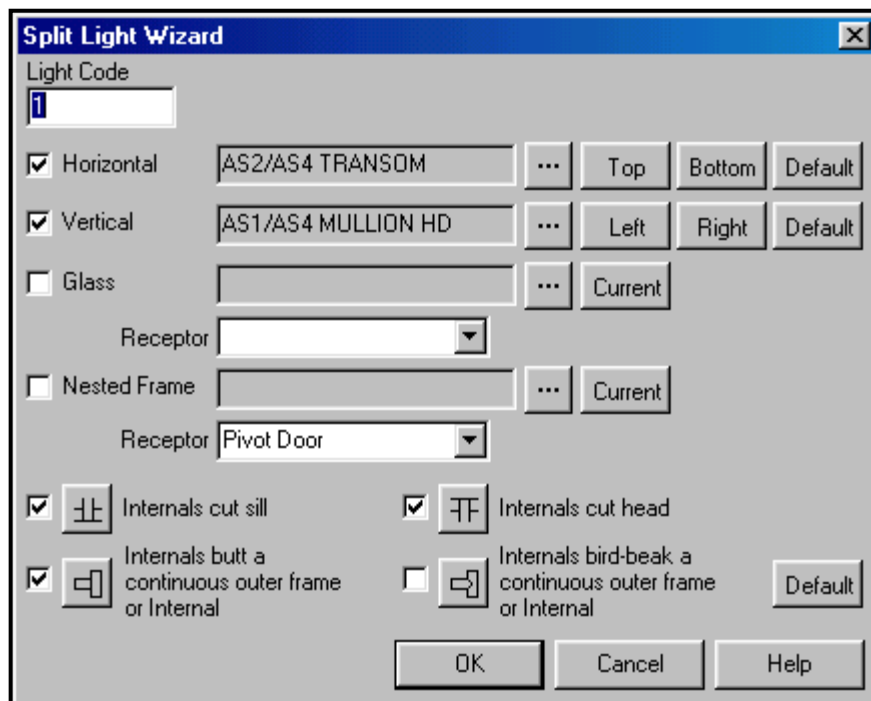

- Enter in a Light Code.

eg. Entering in a 2 will display the following within a light -

Split Light Wizard (Continued)



Entering in a 11 will display the following within a light -

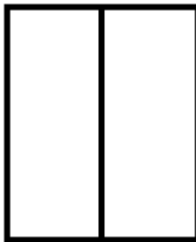

- Select the Assemblies that you want to place on the Horizontal and the Vertical. (These will be set to the default but can be changed here).
- Select the Joints (this will be set to the default).

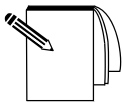

Note: Using the Split Light Wizard on this Tab instead of the Split Light Wizard on the Wireframe tab will set the Joints for you providing these have been selected.

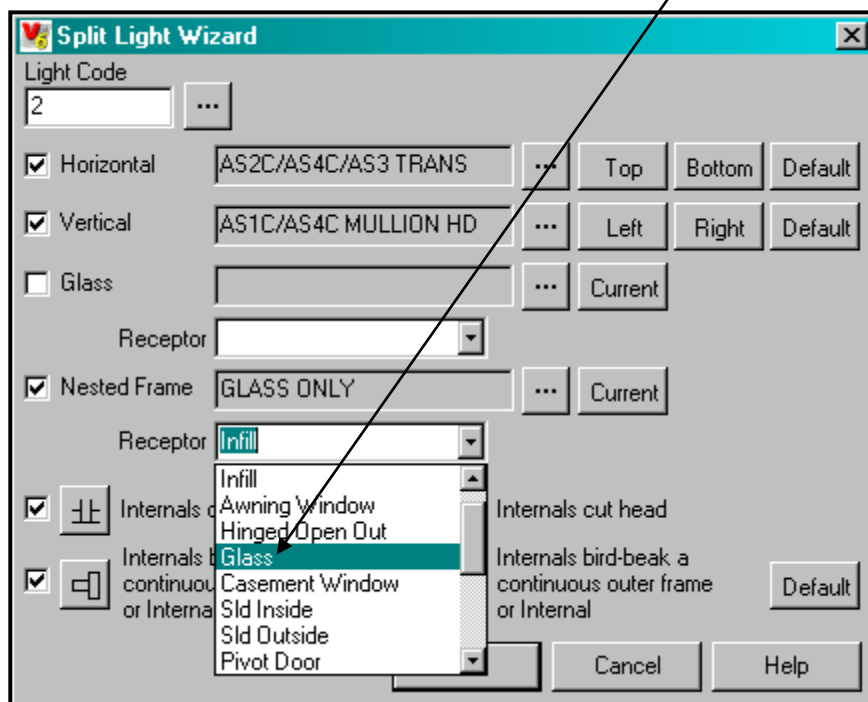

If there is glass in the lite to be split, the correct receptor needs to be chosen.



Horizontal Dimension Wizard



This Wizard allows you to set up a dimension for a Light. This can be done by the following steps –

- Click on the Frame so it is highlighted Red. Click on the  button, to zoom into the Frame.
- Select the Light that you want to place a dimension on.
- Click on the Wizards Tab and click on the  button. This will then display the following screen.

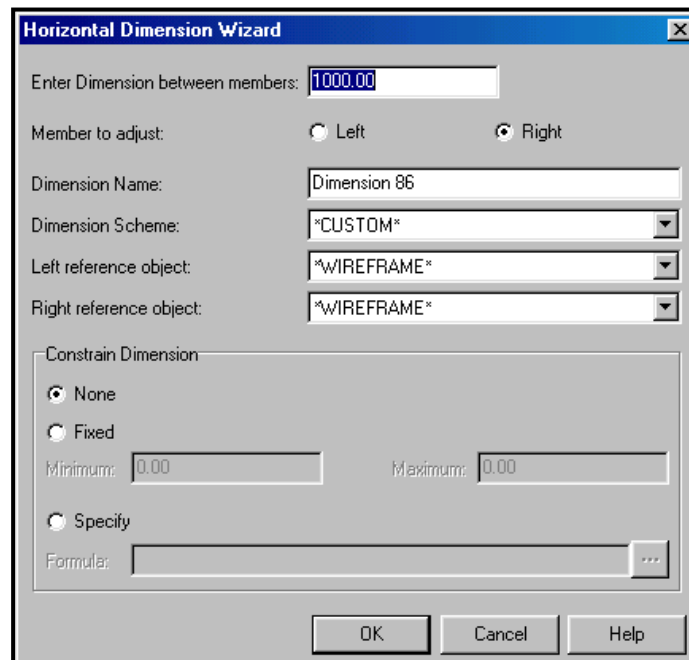

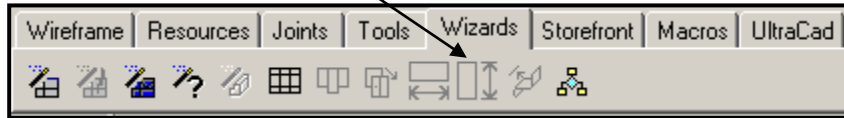

- Enter in the Width that you want to set the Dimension to. (Millimetres).
- Select the Line that you would like to move, either Left or Right.
- Type in a Name for the Dimension.
- Select the Left Reference Object and the Right Reference Object. This will be WIREFRAME.
- Select whether or not you would like to place a Constraint on the Dimension. Entering in Minimum & Maximum Values. This will then stop the user from going below or above these values.
- Or you are able to Specify a Formula.

Vertical Dimension Wizard



This Wizard allows you to set up a dimension for a Light. This can be done by the following steps –

- Click on the Frame so it is highlighted Red. Click on the  button, to zoom into the Frame.
- Select the Light that you want to place a dimension on.
- Click on the Wizards Tab and click on the  button. This will then display the following screen.

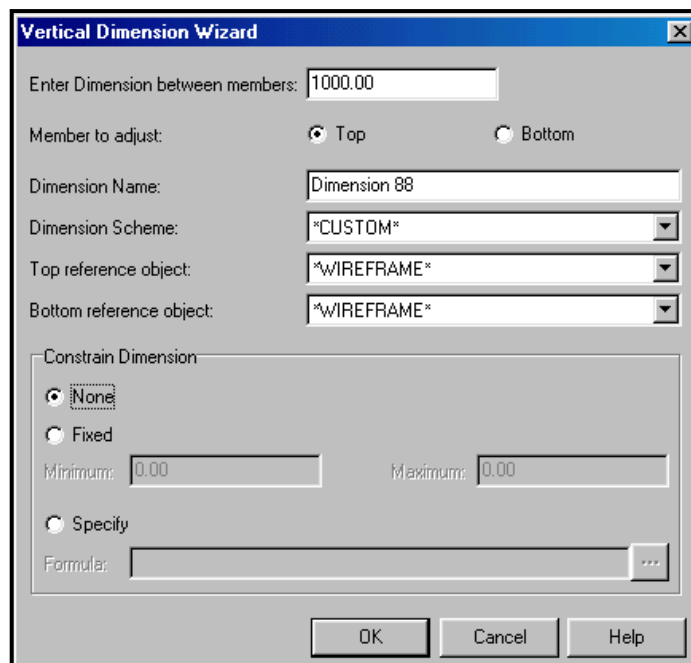

The dialog box is titled "Vertical Dimension Wizard" and contains the following fields and options:

- Enter Dimension between members:
- Member to adjust: Top Bottom
- Dimension Name:
- Dimension Scheme:
- Top reference object:
- Bottom reference object:
- Constrain Dimension:
 - None
 - Fixed
 - Minimum: Maximum:
 - Specify
 - Formula:

Buttons: OK, Cancel, Help

- Enter in the Height that you want to set the Dimension to. (Millimetres).
- Select the Line that you would like to move, either Top or Bottom.
- Type in a Name for the Dimension.
- Select the Left Reference Object and the Right Reference Object. This will be WIREFRAME.
- Select whether or not you would like to place a Constraint on the Dimension. Entering in Minimum & Maximum Values. This will then stop the user from going below or above these values.
- Or you are able to Specify a Formula.

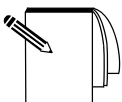

Note: When creating Dimension it is important not to move your frame from the origin (ie. The dotted line on your drawing board). Make sure you select the correct line to move so that you frame does not move off this origin point.

Section 6 - Macro Tab

Doors MACRO

ALSPEC have created a series of Door Macros within their relevant frames to automate this process and ensure no steps are 'missed' by operators.

These can be accessed via the Macro Tab –

There is a choice of Hinged, Pivot and Sliding doors in both the 45mm Swan or Torrens Doors.

The 45mm Swan is shown by the blue icons, the Torrens by the Yellow icons.



Instructions for use of these Macros is explained in the Design Trainer Manual –

Changing Frame Height and Width MACRO



You must be in FACE view to active this (or any macro)

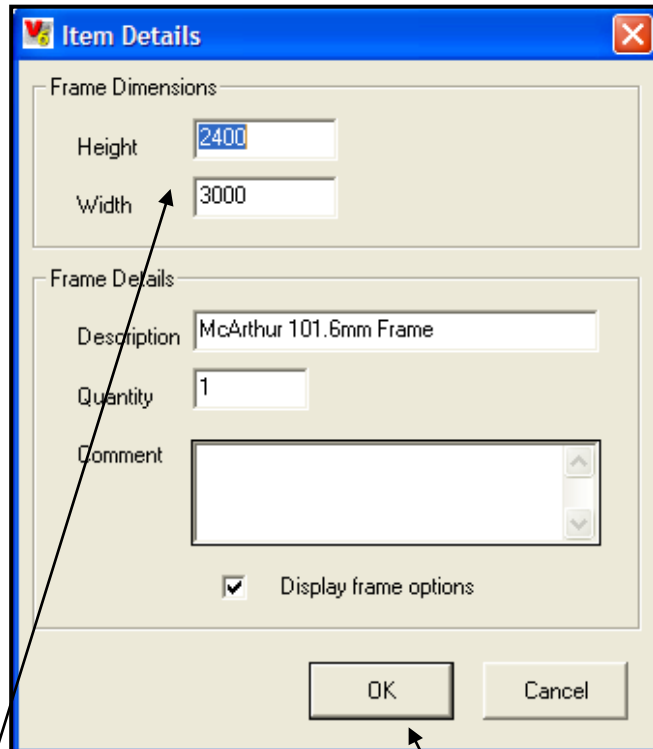

- Enter the changes required and select OK.
- The Frame Options Wizard will then appear with default setting in place, you can make any required changes or just select OK.

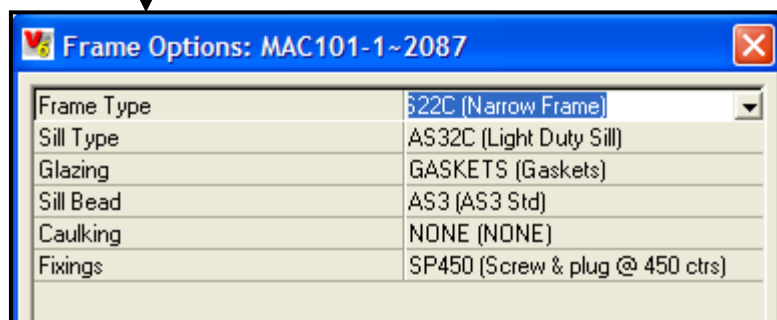

- The Frame in Face View will alter in size accordingly.

Lite By Lite Glazing MACRO

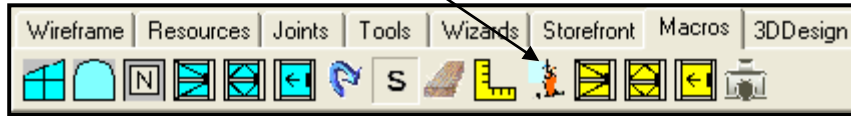

When selected this Macro will display the current frame with **BLUE** edges around each lite which contains Glass. The Glass selected within each lite at this stage will depend on the selection made under DEFAULTS.

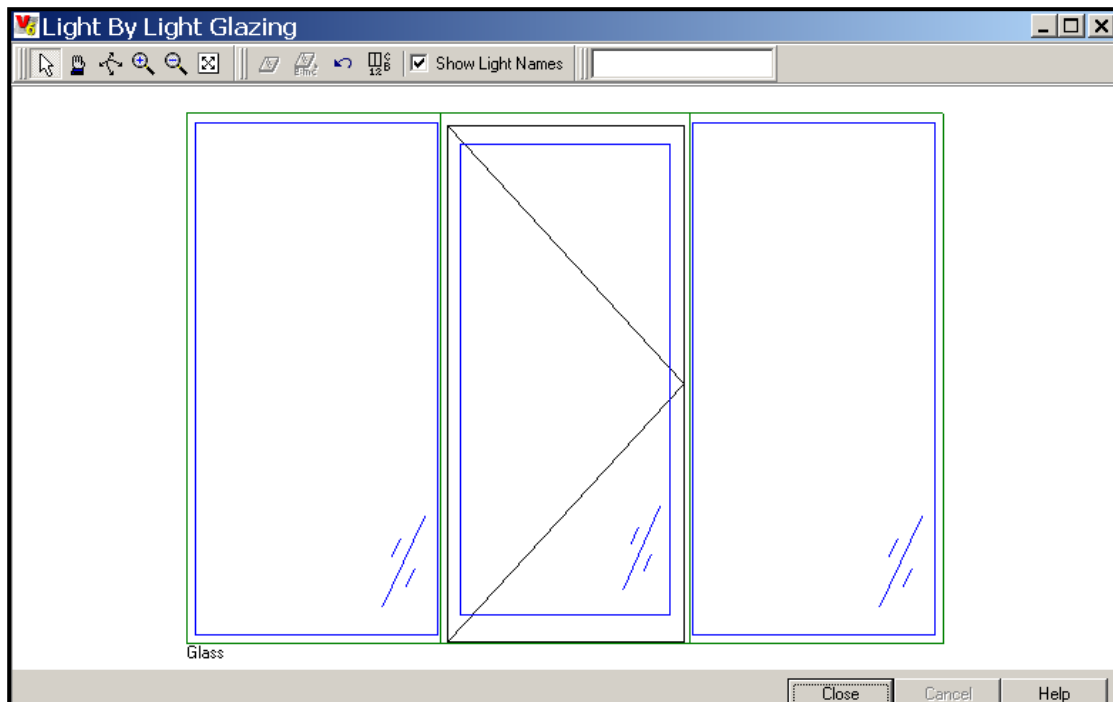

Lite By Lite Glazing MACRO (Continued)

To change any Glass selection already made, simply click on the lite (or lites by holding the SHIFT key down) to be changed and select the **Glass** button.

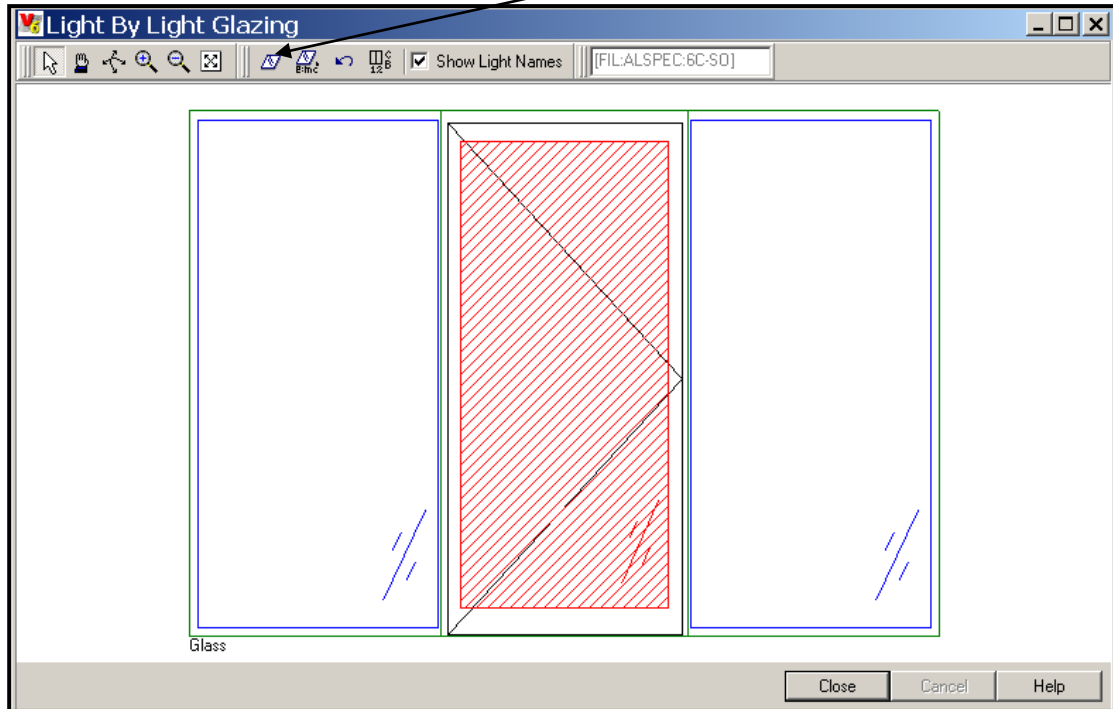

This will take you to the Glass Browser from where you can select the appropriate glass type.

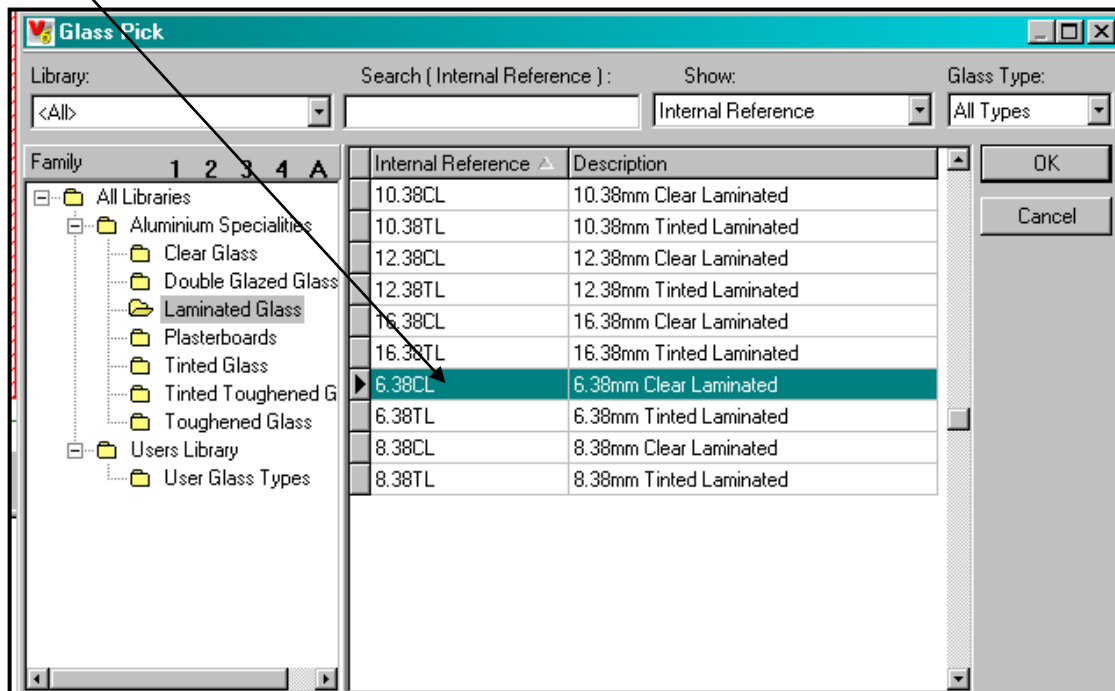

Sub-Head & Sub-Sill MACRO



This Macro is designed to let the estimator select fixing options including Sub Head/Sill and Fixing/Trim Angles to various parts of the frame on the Drawing Board.

Step 1
Select the appropriate Sub-Head

Step 2
Select the appropriate Sub-Sill

Step 3
Nominate Sub-Jamb if required

Step 4
Nominate to change Frame size to allow for fixings

Step 5
Nominate any Over-run for the Sub-Head /Sill.

Step 6
Select the appropriate combination of Angles and location

Step 7
Nominate Frame adjustment for Angles

Step 8
Nominate any Over-run for the Angles.

Step 9
Tick Defaults Box if you wish to keep you set-up for next time and select OK.

Sub-Head & Sub-Sill MACRO (Continued)

The following notification is then displayed to ensure you understand that the Height of the **Frame has been ADJUSTED** to allow for the Sub-Head and/or Sub-Sill combinations

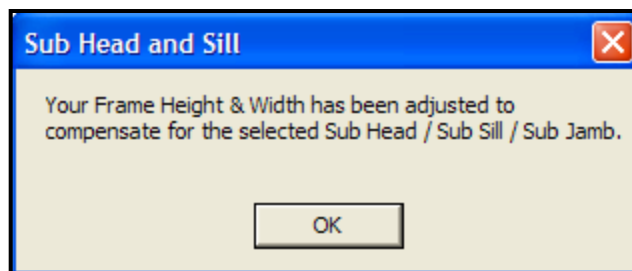

The BOM will now reflect the selected Sub-Head and/or Sub-Sill.

Raked Frame MACRO

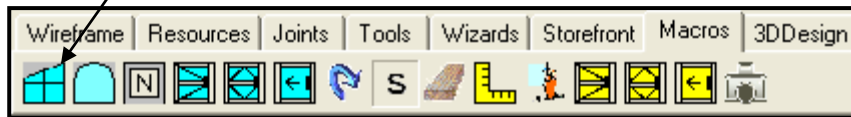

This Macro is designed to lead the estimator through the necessary steps to rake a frame on the Drawing Board.

This Displays the following Box.

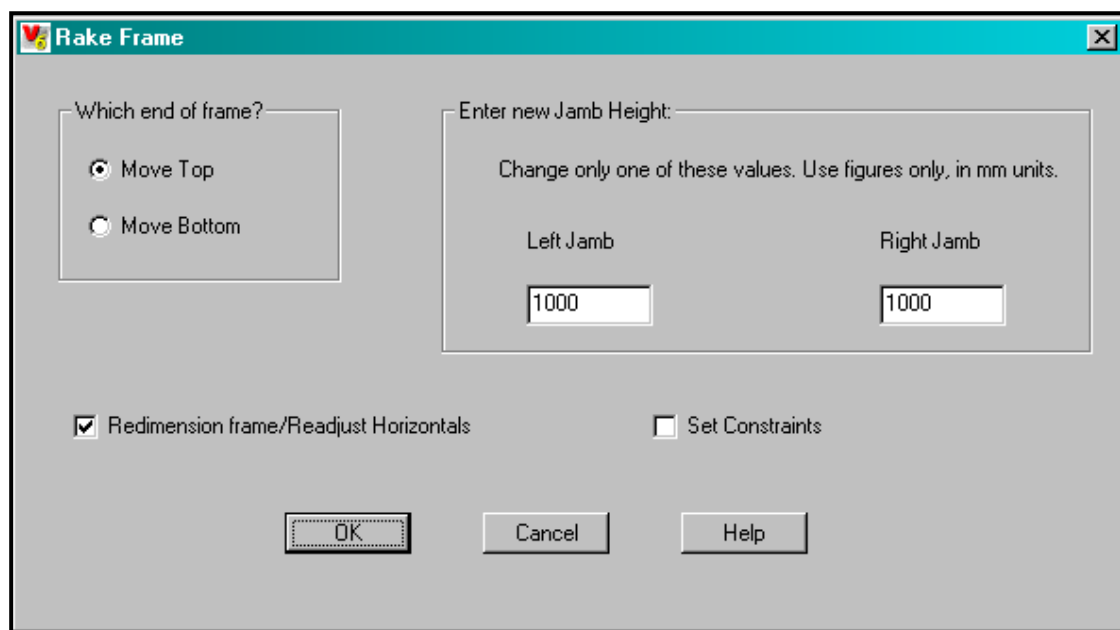

Select which end of the Frame you want to move either Top or Bottom.
Change either the Value of the Left Jamb or the Right Jamb.

E.g. Enter Move Top and Right Jamb 800

Raked Frame MACRO (Continued)

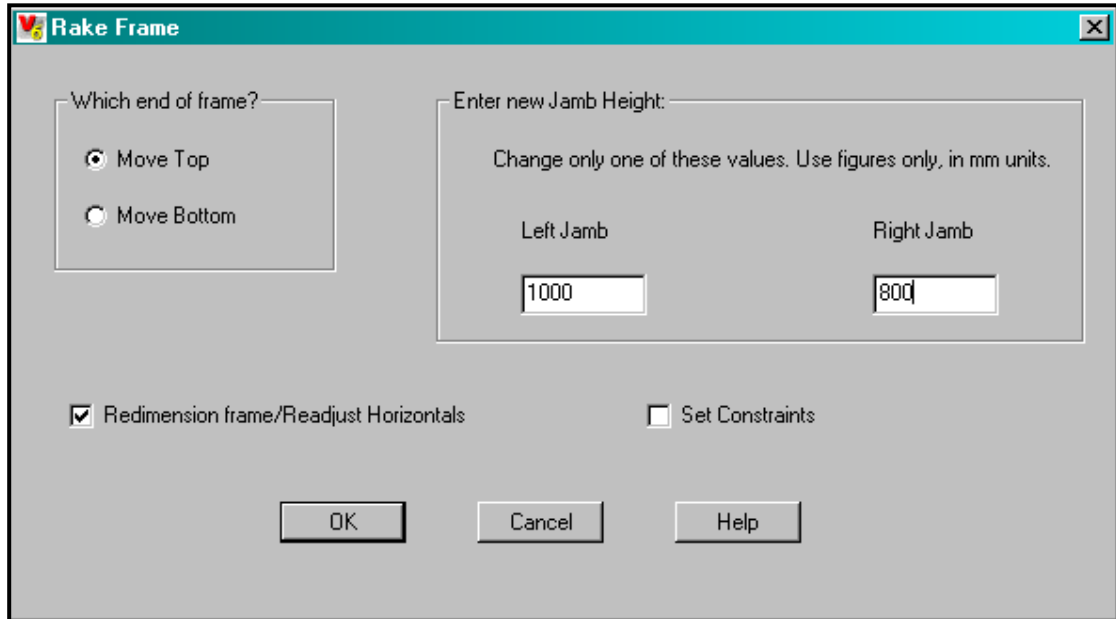

Which end of frame?

Move Top

Move Bottom

Enter new Jamb Height:

Change only one of these values. Use figures only, in mm units.

Left Jamb: 1000

Right Jamb: 800

Redimension frame/Readjust Horizontals

Set Constraints

OK Cancel Help

Will produce the end result of –

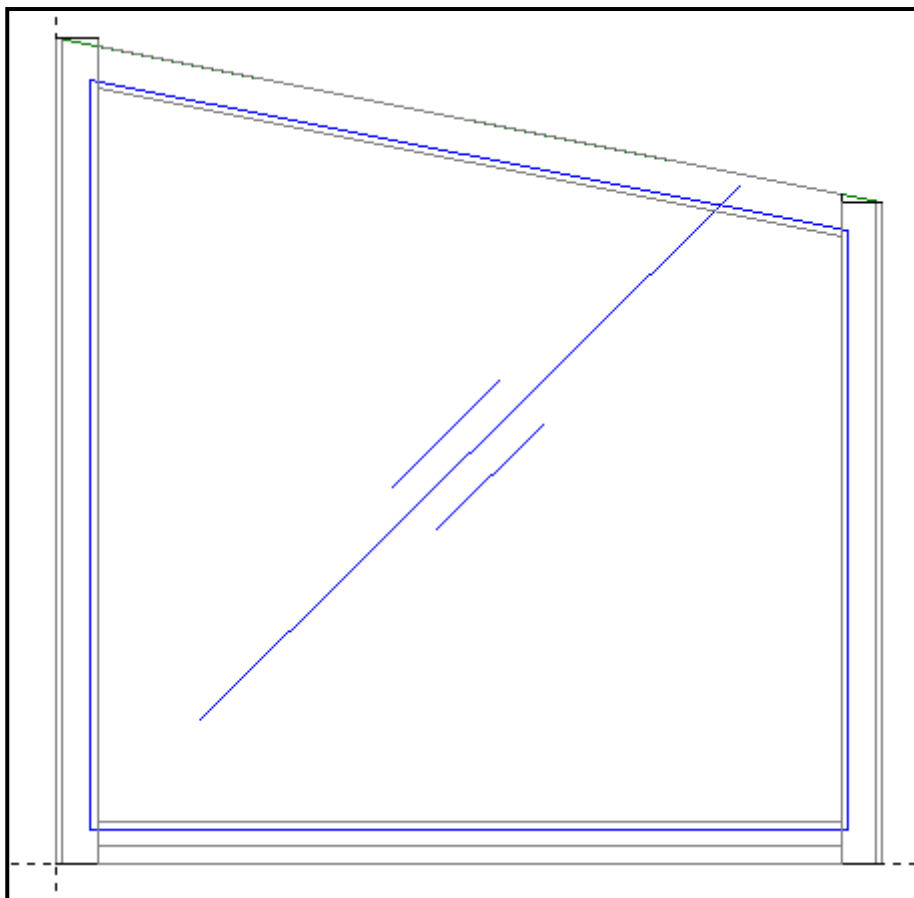

Curved Frame MACRO

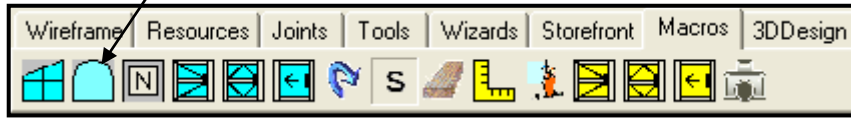

This Macro is designed to lead the estimator through the necessary steps to curve a frame on the Drawing Board.

This Displays the following Box.

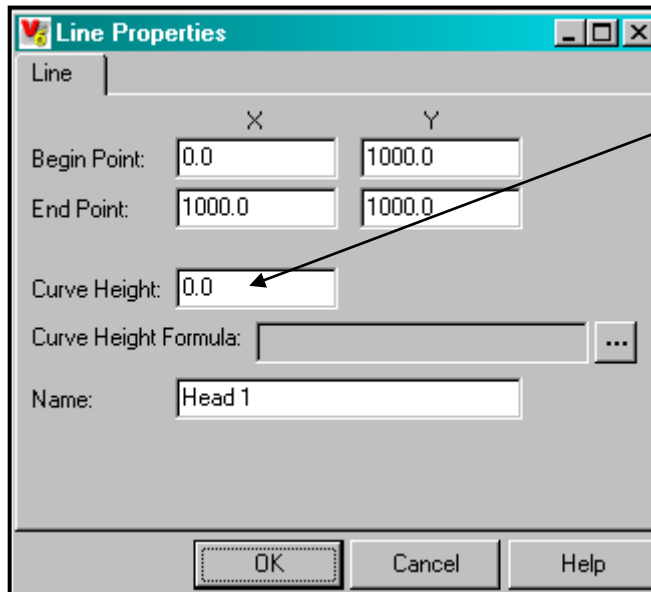

Select the Curve Height
E.g. Enter Curve Height 200

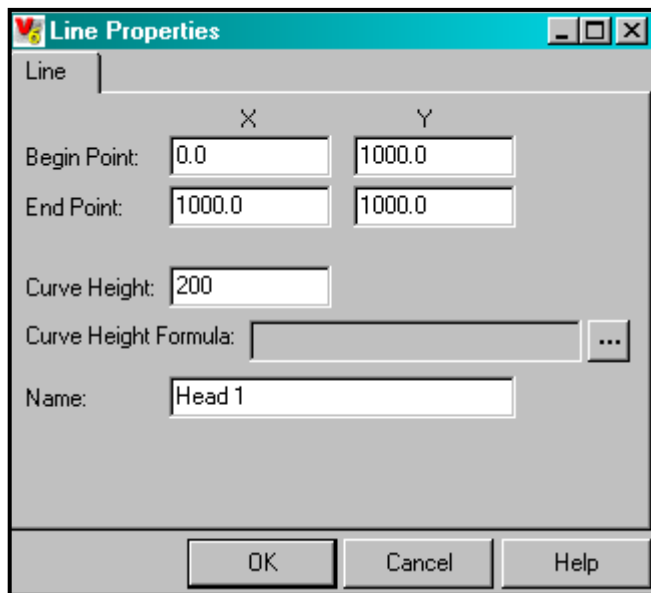

Will produce the end result of –

Curved Frame MACRO (Continued)

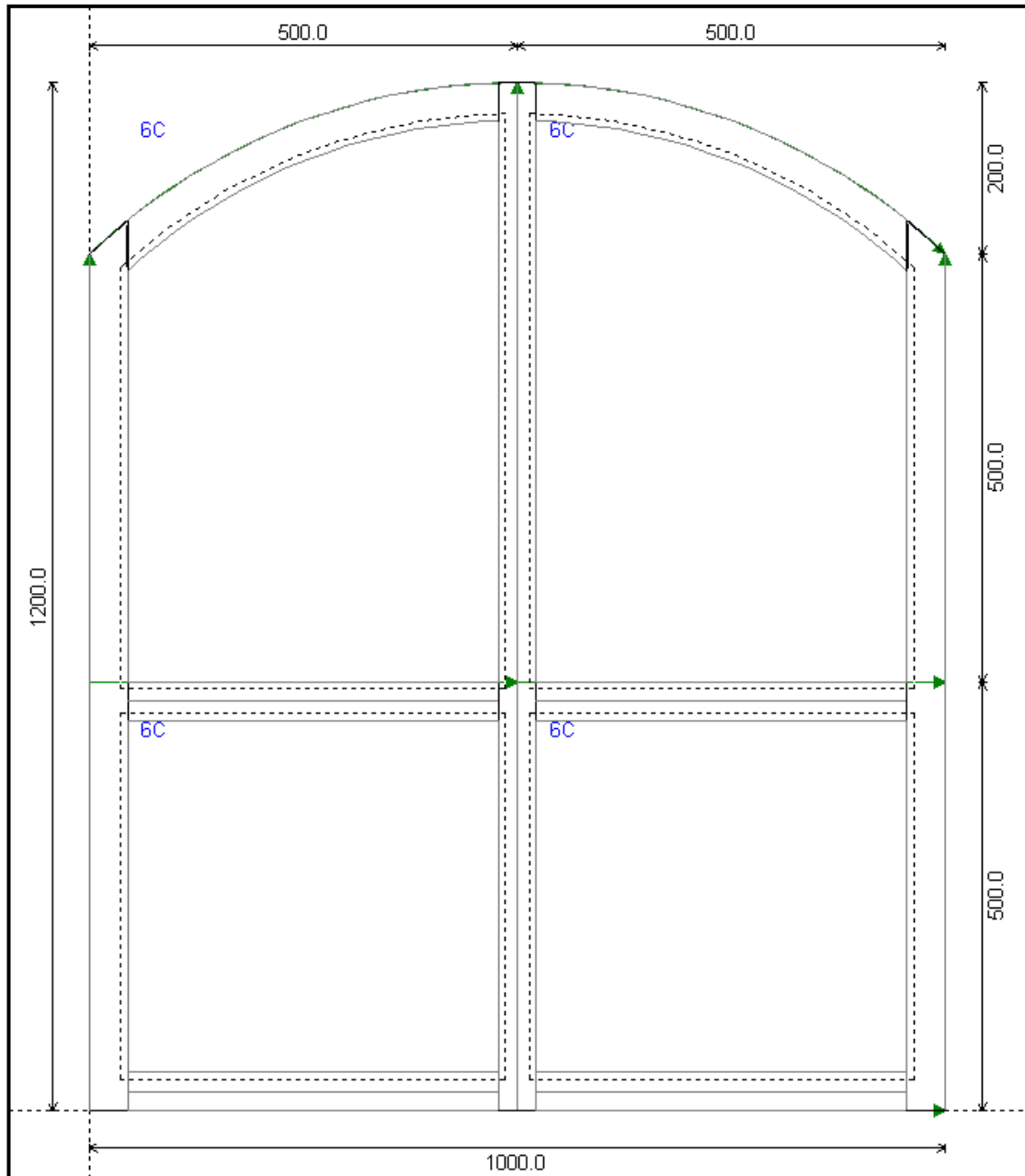

Nested Frame MACRO



ALSPEC have created a Nested Frame Macro within their relevant frames to automate this process and ensure no steps are 'missed' by operators.

A demonstration of this Macro can be viewed in the Design Trainer Manual