

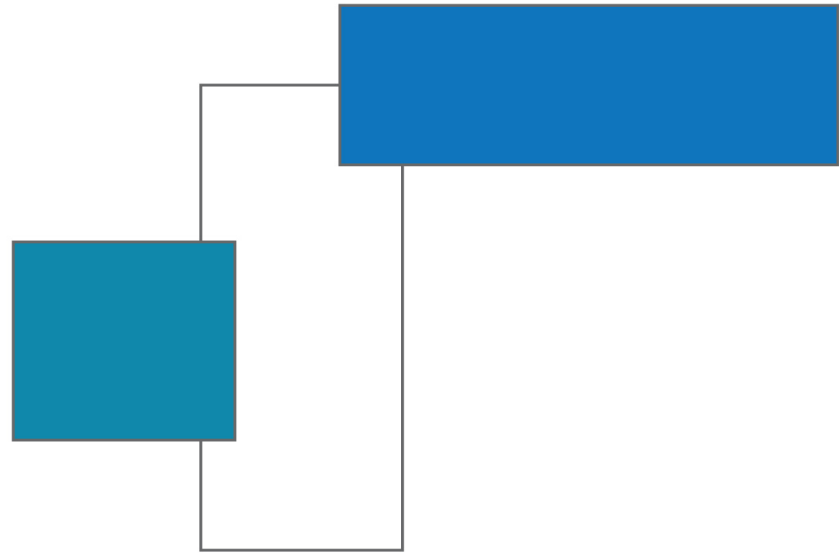

ARCHITECTURAL
FRAMING
SYSTEMS













ADVANCED DESIGN MANUAL



Design Tools - Frame View

General

Select
Pan
Zoom Reset
Zoom In
Zoom Into
Calliper
Rotate
Delete
Zoom Out
Zoom Out of

Icon		Description
Select		Clicking Select allows you to select an object on the Drawing Board. Objects turn red when they are selected. To select more than one object, press the shift key while you select each object.
Pan		Click Pan, and then drag an item across the drawing board to pan from side to side.
Zoom Reset		Returns you to the view you previously had when the drawing board was first opened.
Zoom In		This enlarges the visual display of the selected item.
Zoom Into		Zooms into the currently selected Lite, Face, and Point.
Calliper		The callipers cursor is positioned on the drawing board where you want the X and Y axis to be situated. The cursor's distance from the x-axis, distance from the y-axis and distance from the axis point (i.e. 0, 0) is shown at the bottom of the dialog box. On the frame drawing board, the callipers allow you to define and measure distances between objects.
Rotate		Rotates the frame to the orientation you want.
Delete		Deletes the item you have selected on the drawing board.
Zoom Out		This reduces the visual display of the selected item.
Zoom Out of		Zooms out of the current view.
Disable Mouse Dragging		

Design Tools - Face View

<p>Section 1 - <u>Wireframe Tab</u> Merge Lite Lock / Unlock Points</p>	<p>4</p>
<p>Section 2 - <u>Resources Tab</u> Nested Frames Assembly Substitution Reverse Assembly Merge Assemblies Lites Equal on Height Add Frame View</p>	<p>6</p>
<p>Section 3 - <u>Joints Tab</u></p>	<p>12</p>
<p>Section 4 - <u>Tools Tab</u> Thumbnail Refresh</p>	<p>14</p>
<p>Section 5 - <u>Wizards Tab</u> Options Wizard Assembly Wizard Grid Frame Wizard Stepped Frame Wizard Split Lite Wizard Horizontal Dimension Wizard Vertical Dimension Wizard</p>	<p>16</p>
<p>Section 6 - <u>Macro Tab</u> Can consist of some or all of these depending on the framing system. Grid Frame Macro Door Macro Fixed Lite Macro Awning Window Macro Raked Frame Macro Angle Trim Macro Lit by Lite Glazing Macro</p>	<p>28</p>

Design Tools – Face View

Section 1 - Wireframe Tab

Merge Lite



If you require to Merge Lites this can be achieved by the following steps -

- Select the Lites that you want to merge by either selecting them on the drawing board or under the Objects Tree. (Remembering that if you want to select more than one lite to hold the Shift Key on your Keyboard).
- Click on the Wireframe Tab and click on the merge lites button .
- This will display the following box asking you which lite you would like to keep.





- Once you have selected the Lite you would like to keep then click on the  button. This will then merge the Lites.

Lock and Unlock Points



When you are creating a Frame by default the Points are Unlocked. When you lock Points and Lines these will move as one.

- Drag your mouse over the Lines and Points that you want to lock so these are highlighted red. (See the following picture).
- Then click on the  button to Lock the points. Or to Unlock the points click on the  button.

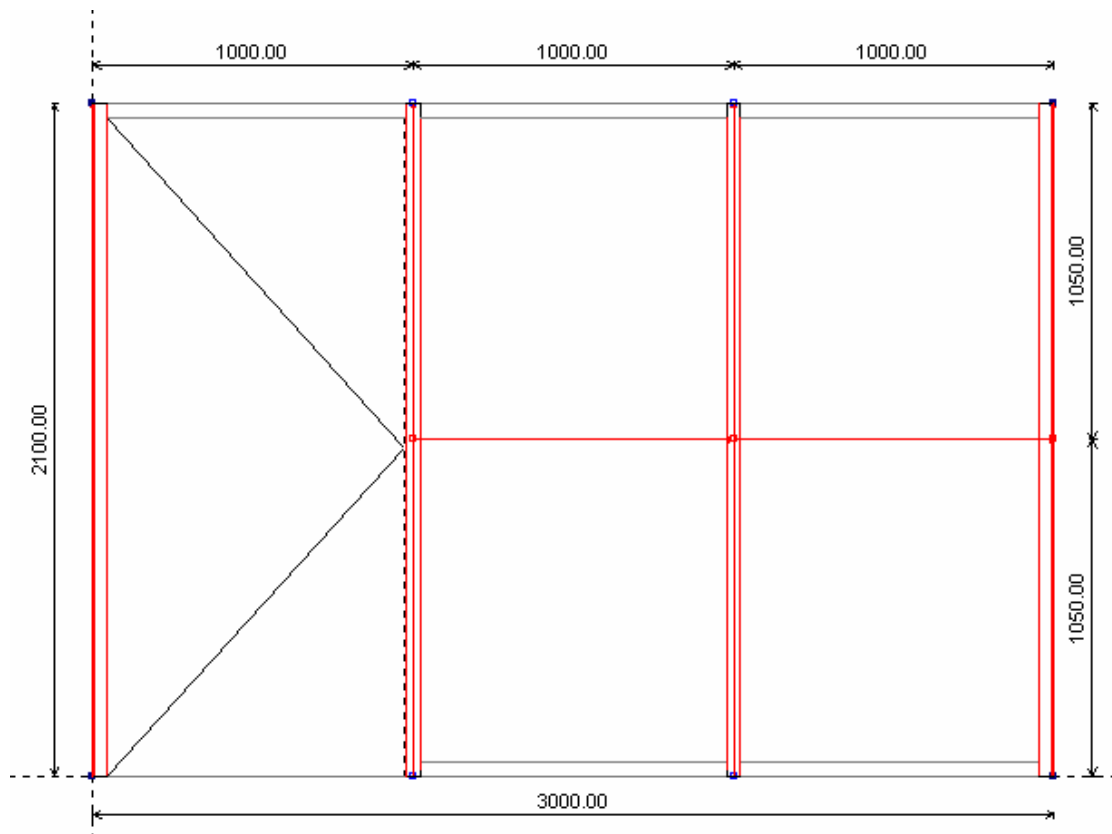

- You will notice that we have used the Locked Points to Move a Line which will become our Transom in this Frame. Therefore the two lines will move together.

Section 2 - Resources Tab

Nested Frame



To Nest a frame use following steps -

- Select the Lite so it is highlighted red. Click on the Resources Tab and click on the following icon .
- This will display a Frame Picker Browser, from here you can select the frame to nest.

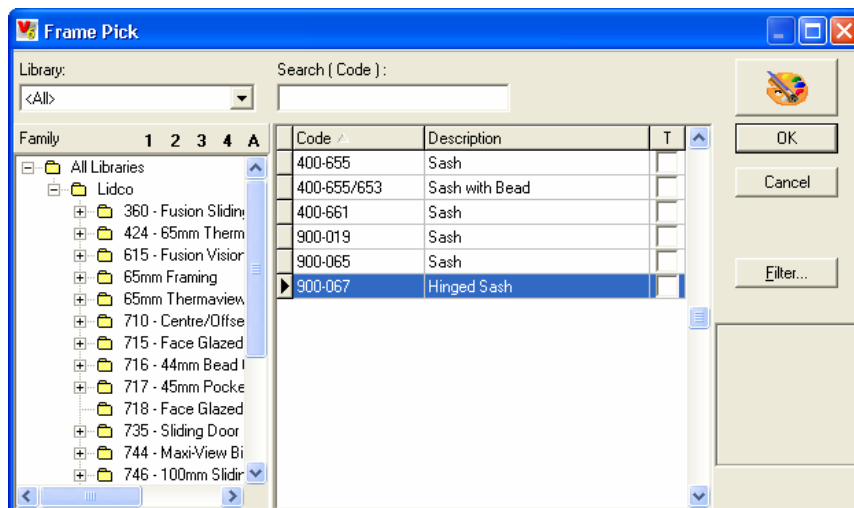

- Select from the list then click on the  button.
- This will then display a "Place in Receptor?" box, like the following.

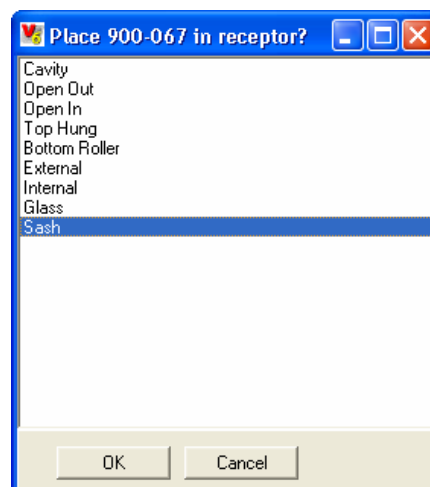

- Select the appropriate receptor and click OK to populate the frame

Assembly Substitution



If you require a different Assembly to the one that you first selected you are able to use the Substitution icon.

- Select the Assembly which you want to Substitute, by selecting it in the Objects Tree.
- Click on the Resources Tab and click on the  button.
- This will bring up an Assembly Picker Box, select the Assembly you require and click on the button.
- This will then Substitute the Assembly for the one that you have selected.

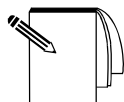
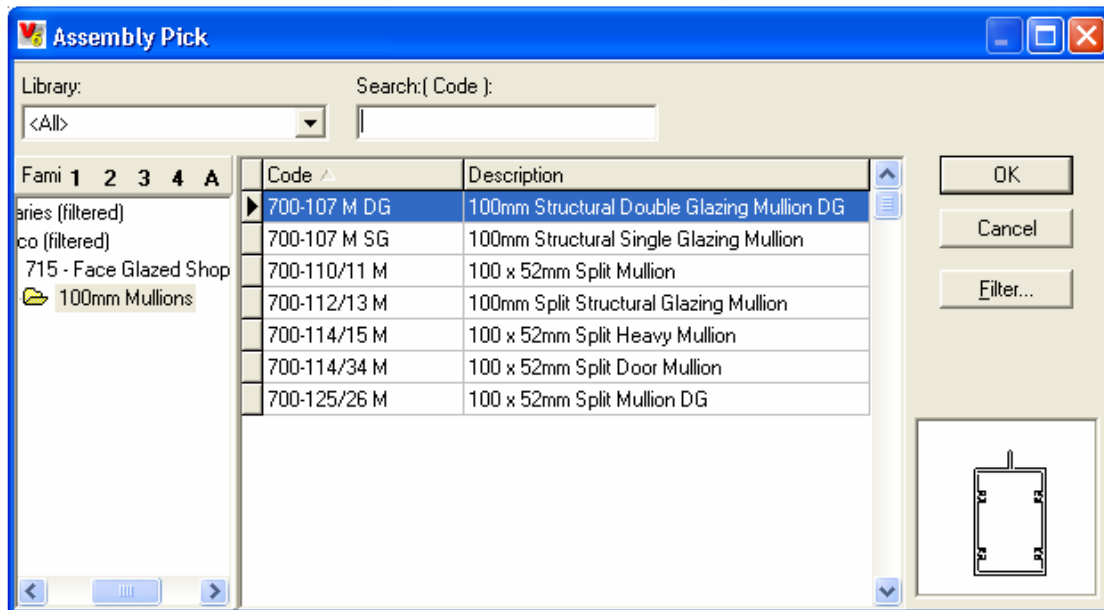

Note: If the Assembly that you have selected does not substitute make sure to check that your joints have remained.

Reverse Assembly



Once you have placed an Assembly onto your frame and if you notice that the Extrusion you require is on the wrong side you can select Reverse Assembly. This will reverse the Assembly.

- Select the Assembly that you want to Reverse, by selecting it in the Objects Tree.
- Click on the resources tab then click on the following icon , this will reverse the Assembly.

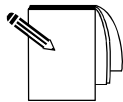

Note: This should not need to be used as the database has been designed to orientate the assemblies the correct way around.

Lites Equal on Width



If you require to make the Lites Equal on Width this is achieved by the following –

- Select the Lites that you want to make equal, by clicking and selecting them on your drawing board, remembering to hold the Shift Key on your keyboard to select more than one.
- Click on the Resources Tab and then click on the  button.
- This will then display the following box, asking you to select which Receptor to use.

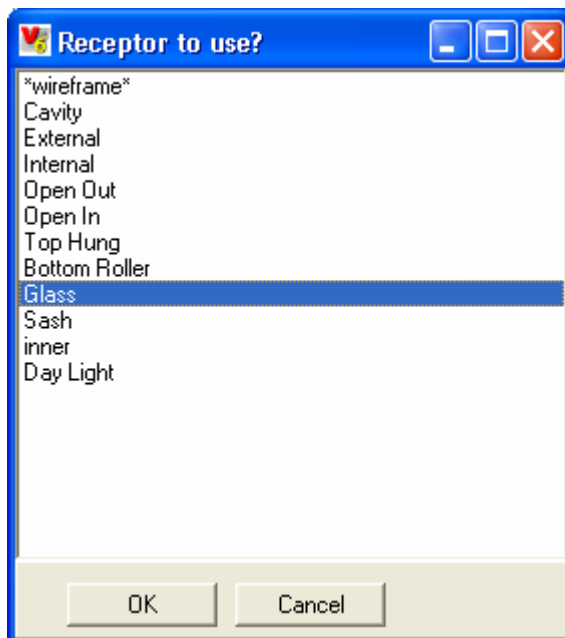

- Select the Receptor and press the OK Button.

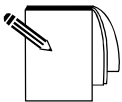

Note: To achieve equal Glass and Equal Heads and Sills use the Glass or Daylight Receptor.

Lites Equal on Height

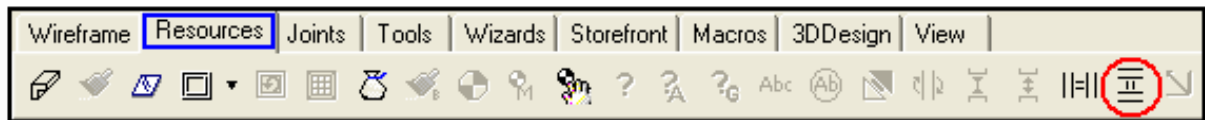

If you require to make the Lites Equal on Height this is achieved by the following –

- Select the Lites that you want to make equal, by clicking and selecting them on your drawing board, remembering to hold the Shift Key on your keyboard to select more than one.
- Click on the Resources Tab and then click on the  button.
- This will then display the following box, asking you to select which Receptor to use.

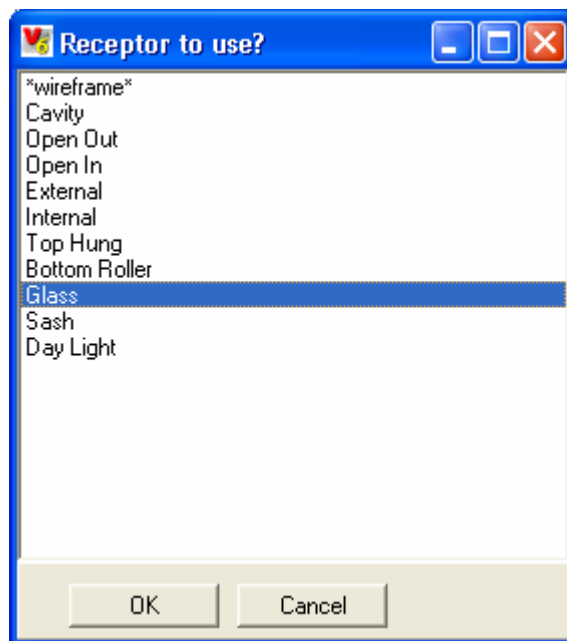

- Select the Receptor and press the OK Button.

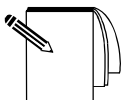

Note: To achieve equal Glass use the Glass or Daylight Receptor.

Add Frame View



Frame View is denoted by a graphic of a video camera .
You must be in **Frame View** to use this function.

Frame View allows the estimator to capture a snap-shot of the frame at any angle or view they wish. Simply generate the view or rotation you wish and press the  button. This Frame view taken is added to the Objects tree from where it can be viewed at any time.

To view a previously saved Frame View –

1. Select the View from the Object tree
- 2) Right-click and select EDIT

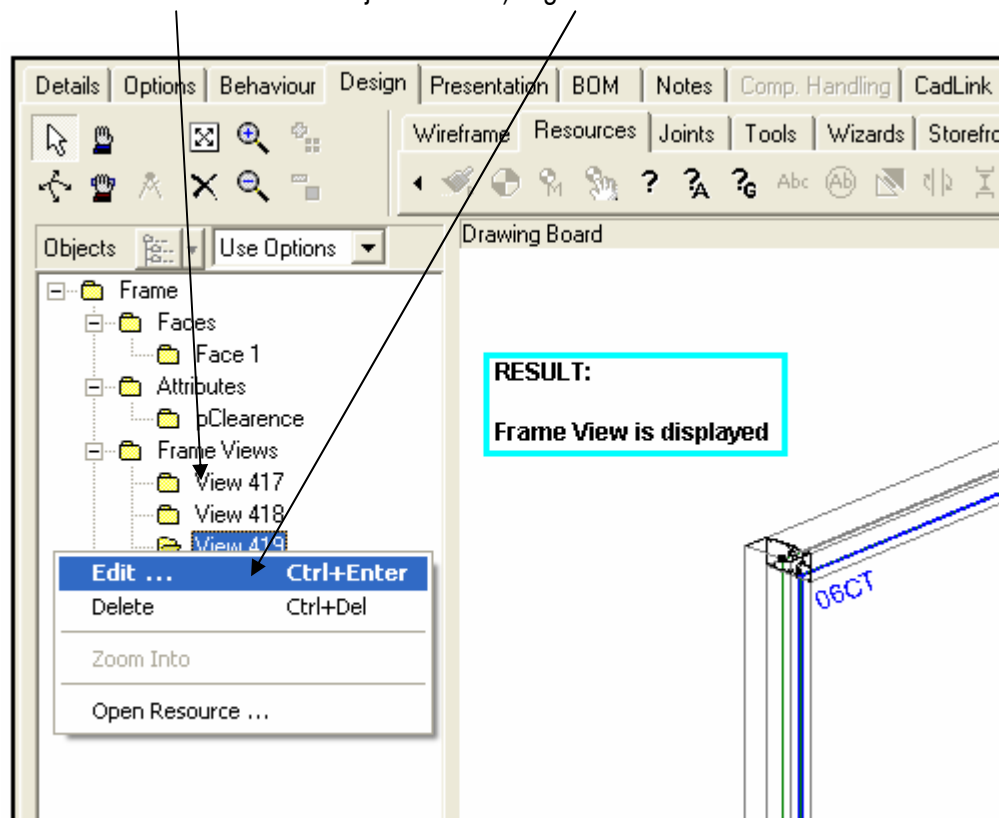

Frame View snap-shots are also available for use within the Presentation tab.

Section 3 - Joints Tab



This function is generally taken care of automatically when the grid frame wizard is run but can be useful if a joint is not correct.

Instructions below explain how to correct a cut.

- Click on the Joints tab.
- Make sure you have your Points Displayed on the Drawing Board. Right Click and go to Display. Make sure the Point has a check next to it.
- Select one of the Points on the outer Frame. This can be done by either clicking on the point on the Drawing Board or selecting it in the Objects tree on the left hand side.
- Click on the  button and this will zoom into the point you have selected. This will then look like the following.

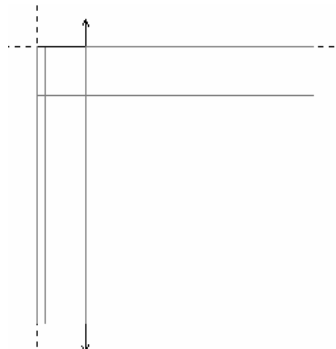

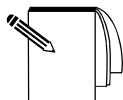
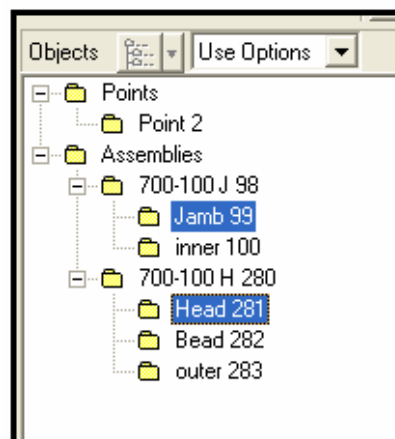

- You now need to select the Extrusion and the Buttline you would like to join. This is done by holding the Shift Key on your Keyboard and selecting the two from the Objects Tree on the Left hand side. See the following picture.

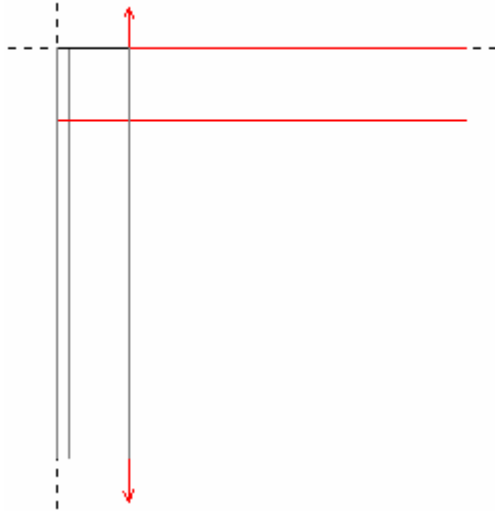

Note: All the Butt Lines are in Upper Case and all the Extrusion names are in Proper Case.

- The drawing board will then look like the following.



- You will notice that our Head Extrusion has been selected and our HEAD/SILL buttline has been selected. We can now join the two.
- Click on the  button and this will join the two. Your Drawing Board should now look like the following.

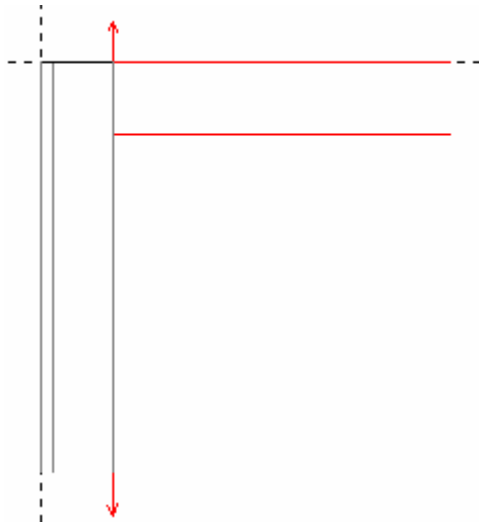

- You will notice that the two have joined. You will need to repeat these steps for all of the Points that you would like to join.

Section 4 - Tools Tab

Thumbnail



When you create a Frame in the Design View you are able to take a Thumbnail. This is a picture of your frame that you have created. This picture will then be placed on your reports. The Thumbnail can be taken either when you are Zoomed Into the Frame or Zoomed out of the Frame.

You may want certain things not to be displayed when you take a Thumbnail such as the Points for a neater appearing picture. To do this Right Click on the Drawing Board and click on Display. The following menu appears.

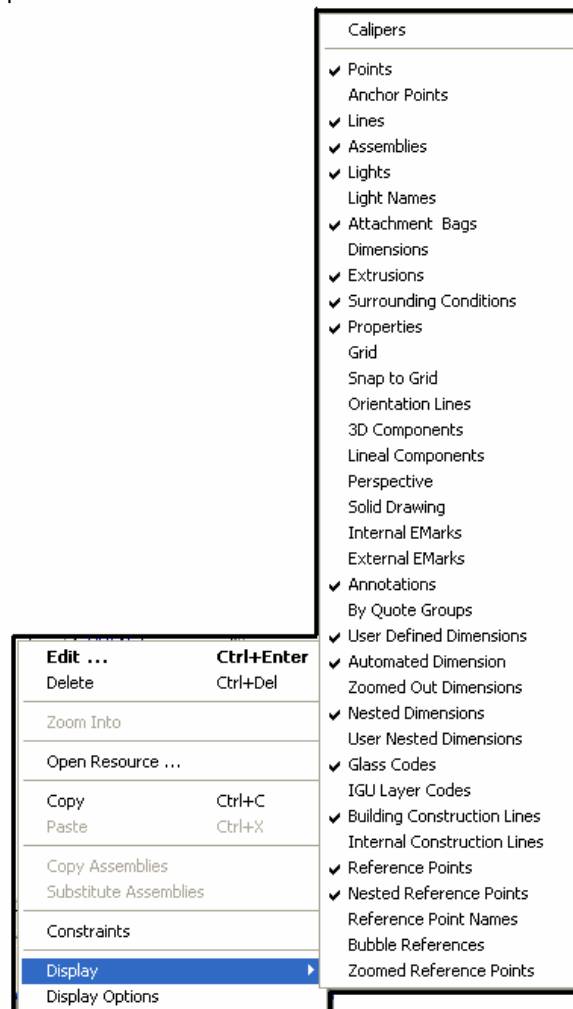

From this menu you can select or de-select what you require or don't require.

Click on the Tools tab and then click on the  button. You will notice that a Thumbnail now appears on the bottom Left Hand corner of the quote of that particular item.

Refresh



To Refresh the view within the Design Tab click on the Tools tab and click on the , this will refresh the view.

Section 5 - Wizards Tab

Options Wizard



Here you are able to select Finishes, Glass and change Frame Options.

- Click on the Wizards Tab then click on the  button. This will display the following screen.

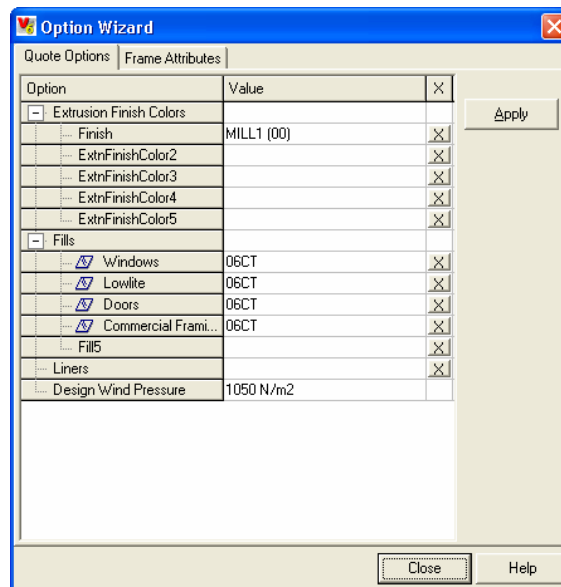

From within this screen you are also able to change frame options.

- Click on the Frame Attributes Tab. Here it lists all the available options for that frame.
- Clicking next to a frame option will bring down a drop down menu allowing you to select from the choices listed. This can also be done from within Options/Edit Options Tab.

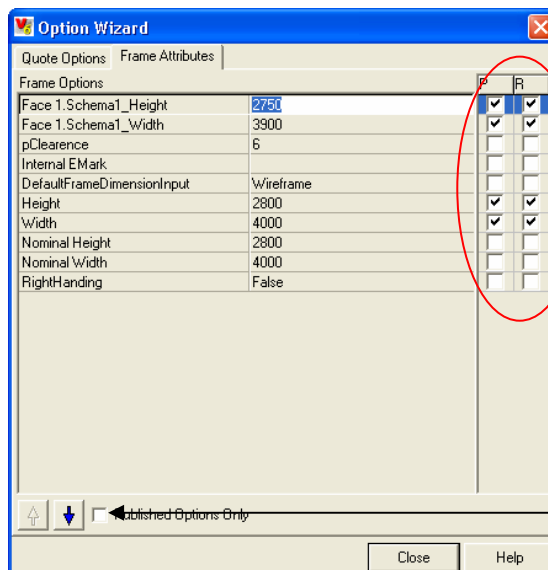

Take care not to check/uncheck these boxes

A tick in this box will show only the options you can select

Grid Frame Wizard



Each Frame Group within the LIDCO database has a **DESIGN** frame.

IT IS STRONGLY ADVISED that you use this **DESIGN** frame whenever a special shape/style is required.

Once you have added your Design Frame (by adding a standard existing frame) to the Quote it is now time to create the frame using the **Grid Frame Wizard**. The Grid Frame Wizard allows you to create a complete frame.

- Click on the Design Tab from within the Quote - Select the Wizards Tab and Click on the following icon , this will then display the following screen.

The screenshot shows the 'Grid Frame Wizard' dialog box with the following fields and options:

- Frame Dimensions:** Enter the Frame Width and Height. Height: 2800, Width: 4000.
- Shim Spacing:** Left: 0, Bottom: 0, Top: 0, Right: 0. Each field has a '...' button to the right.
- Layout:**
 - Number of Rows: 2
 - Number of Columns: 4
 - OR
 - Light Code: 1
 - Create Frame with Equal Lights
- Buttons: Custom >, OK, Cancel, Help.

Enter the Frame Height & Width

Enter in the Height and Width of the frame. (Millimetres)

Layout

Enter in the Number of Rows (i.e. Horizontals) and/or enter in the Number of Columns (i.e. Verticals).

Lite Code

If the number of rows is to be different for each column, enter a lite code in this field. Entering a lite code (instead of columns and rows) can create frames that have a different number of lites in each column. Eg. A lite Code of 213 will draw the following Wire Frame. i.e. 2 Lites, 1 Lite, 3 Lites.

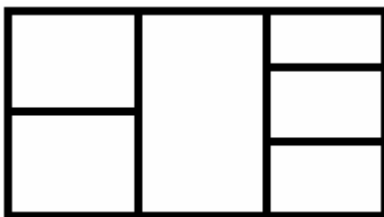

Create Frame with Equal Lites

Check this box to create equal lites.

- Clicking on the Custom button will present the following screen.

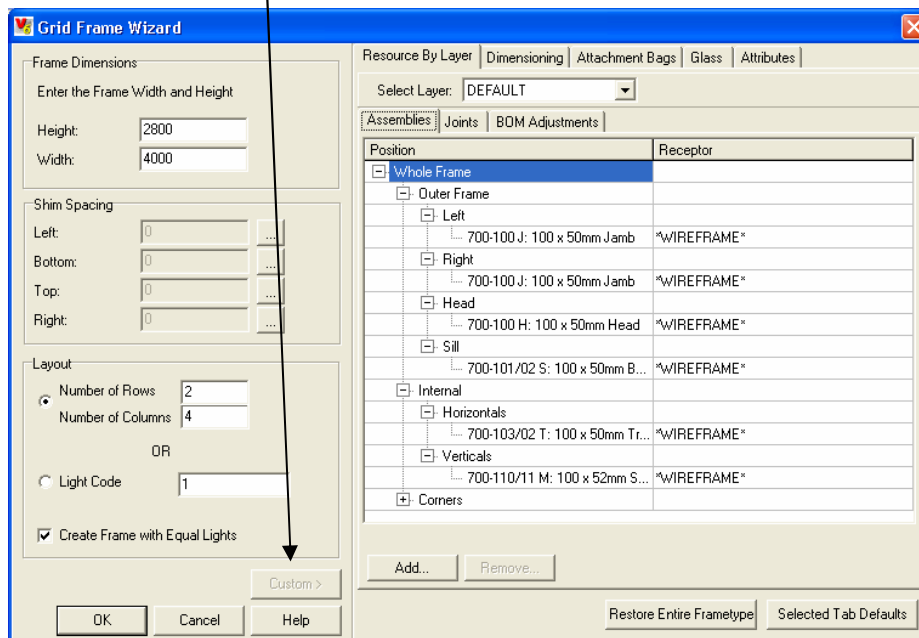

Assemblies Tab

This tab allows you to select the Assemblies that are going to be placed onto your Wireframe. These will be set to defaults but you are able to select others by clicking on the  Button will bring up an Assembly Browser.

Select from the list then click the  button. Repeat this step until you have placed Assemblies on all of the Lines.

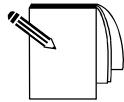

Note: For internal lines such as Transom and Mullions if you have selected more than one, these can be selected here and then Substituted at a later stage. Please see steps that follow.

Glass Tab

This tab allows you to select the Glass that you require for the Frame. This can also be done on the Items/Options Tab, Edit Options.

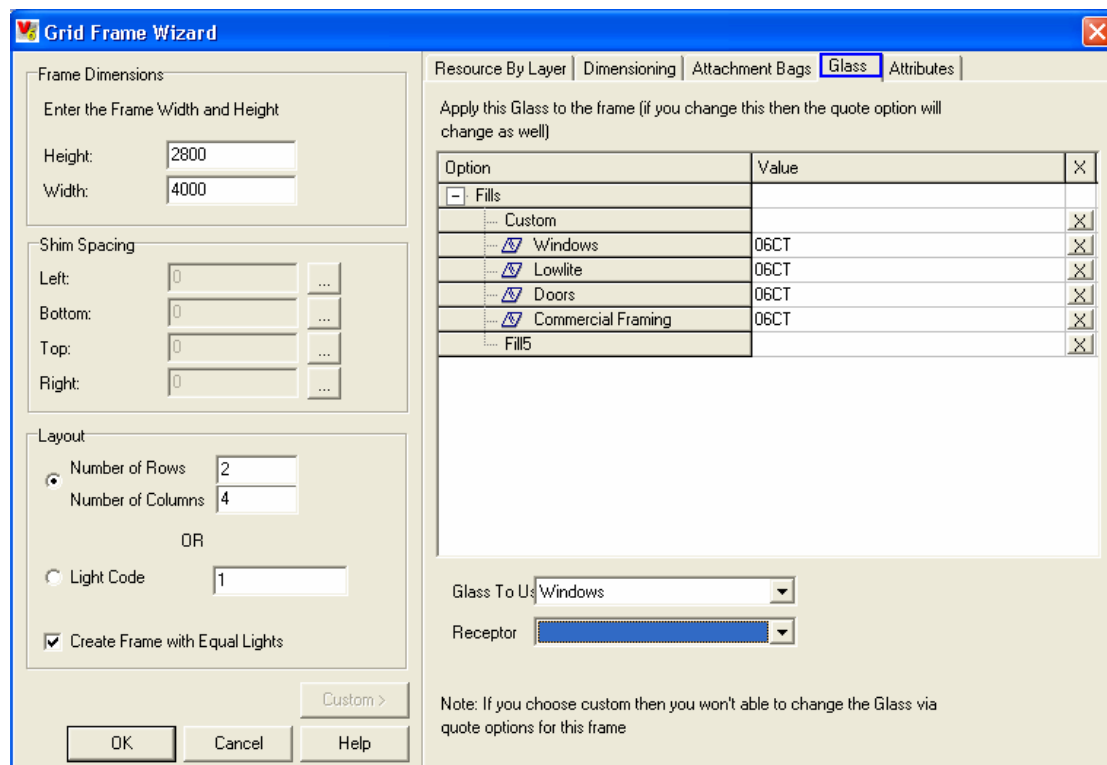

The screenshot shows the 'Grid Frame Wizard' dialog box with the 'Glass' tab selected. The left pane contains settings for Frame Dimensions (Height: 2800, Width: 4000), Shim Spacing (Left, Bottom, Top, Right: 0), and Layout (Number of Rows: 2, Number of Columns: 4, or Light Code: 1, with 'Create Frame with Equal Lights' checked). The right pane shows a table of glass options to be applied to the frame.

Option	Value	
- Fills		X
... Custom		X
... Windows	06CT	X
... Lowlite	06CT	X
... Doors	06CT	X
... Commercial Framing	06CT	X
... Fill5		X

Below the table, 'Glass To Use' is set to 'Windows' and 'Receptor' is set to a blue bar. A note at the bottom states: 'Note: If you choose custom then you won't be able to change the Glass via quote options for this frame'.

Joints Tab

This tab allows you to set the joints for the Outer Framing. The default joints are the following.

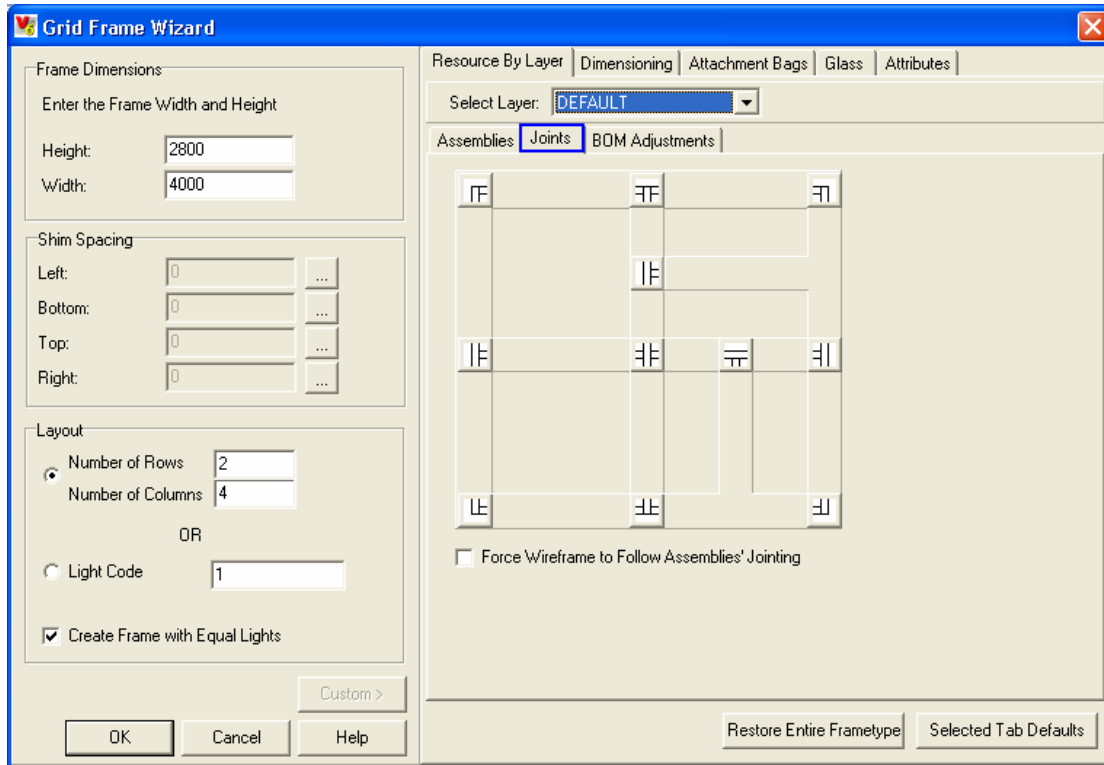

Hover your mouse on the joint you wish to change and a menu will appear. You can select a new joint from this menu.

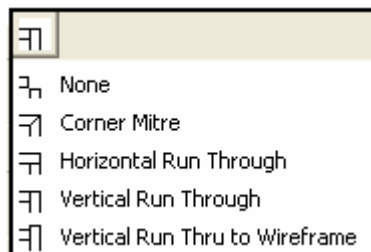

Click on the **OK** button once you have finished this will then populate your Wireframe.

Your drawing board should now look like the following-

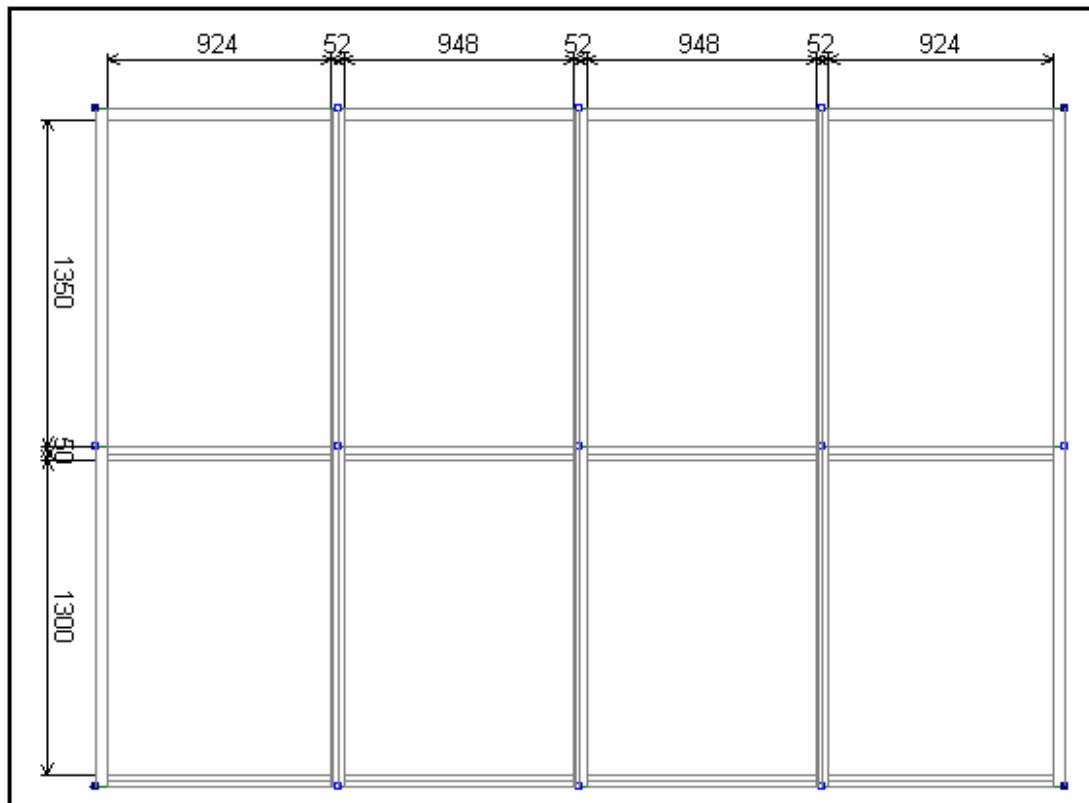

Stepped Frame Wizard



To create a frame with a stepped sill in V6, you must first create a rectangular frame with all assemblies and fills, and then remove a portion of the frame. The Stepped Frame Wizard performs the removal.

The Wizard will need a Head or Sill Assembly to be selected in order to complete the operation. It will remove all the Assemblies on the Head, Sill, left and right Jamb surrounding the Lite, and split any up if necessary. The first internal horizontal assembly found will be substituted for the new head or sill assembly.

A step will be created where at least two lites exist, one of top of the other. In the case where only one lite exists the entire lite including head/sill and fill will be removed.

V6 will automatically shorten vertical Assemblies – such as Jamb and Mullions, and will remove Lites and Fills, and place sill assemblies along the new edge and reconstruct all joints during the process.

- To Step a Frame, Click on the lite so it is highlighted Red

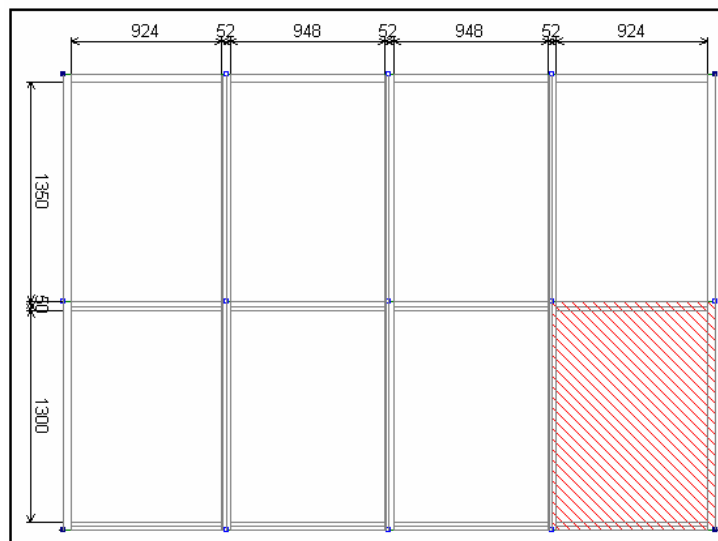

- Click on the Wizards Tab and click on the  button.
This will display the following box –

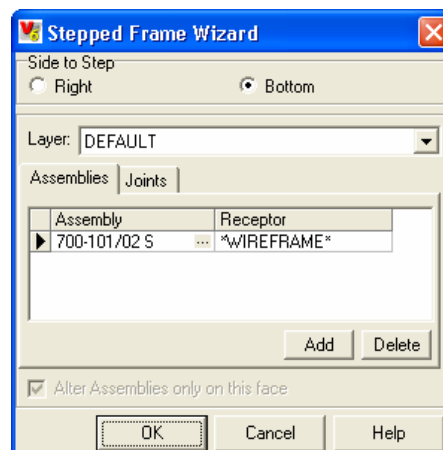

- Click OK.
- Your drawing board will then look like the following –

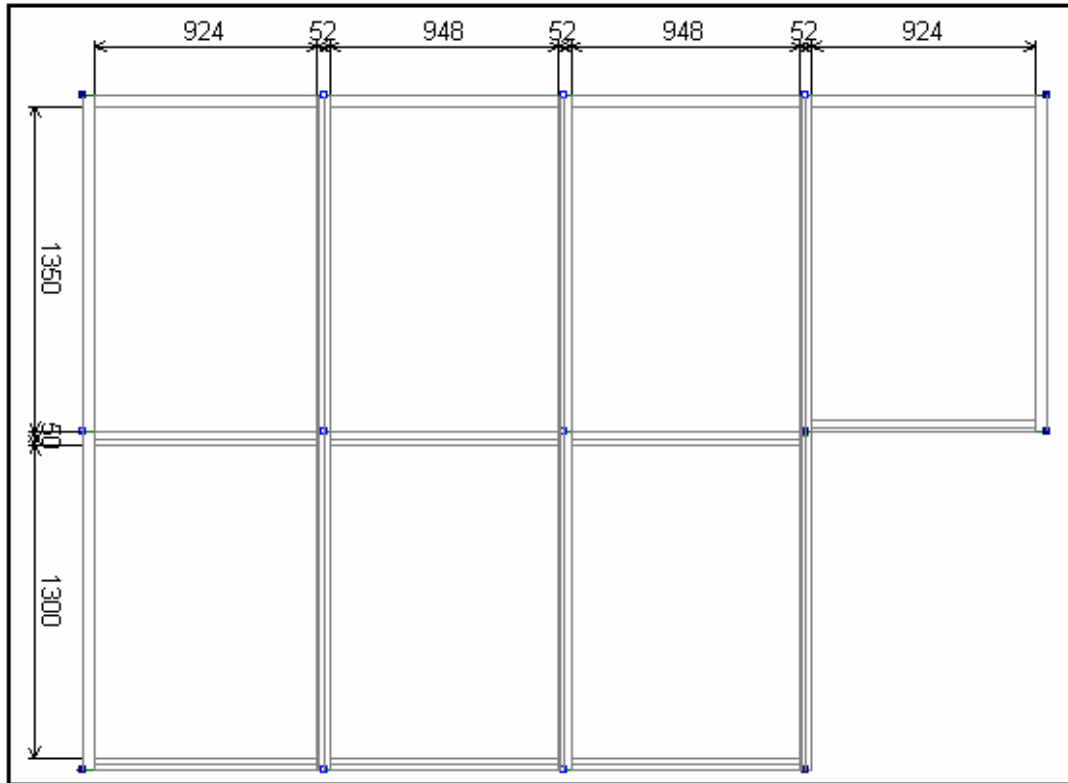

Split Lite Wizard



If you require to Split the Lites this is achieved by the following steps –

- Select the Lite or Lites that you want to Split.
- Click on the Wizards Tab and click on the  button.
- This will then display the following box.

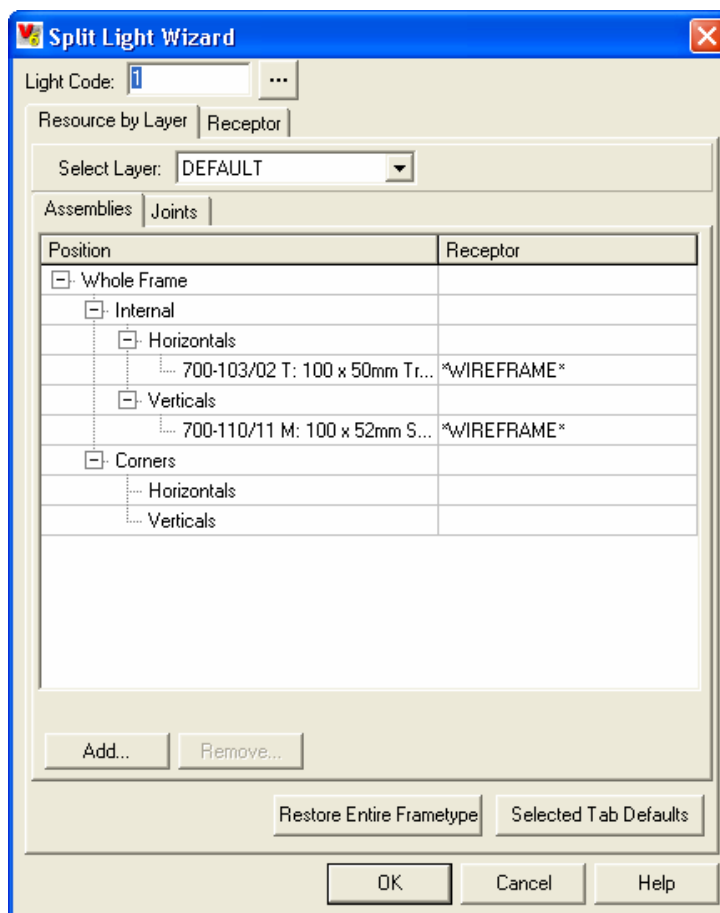

- Enter in a Lite Code.

eg. Entering in a 2 will display the following within a lite -

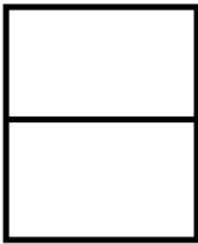

Entering in 11 will display the following within a lite -

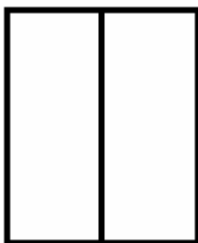

- Select the Assemblies that you want to place on the Horizontal and the Vertical. (These will be set to the default but can be changed here).
- Select the Joints (this will be set to the default).

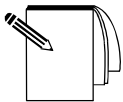

Note: Using the Split Lite Wizard on this Tab instead of the Split Lite Wizard on the Wireframe tab will set the Joints for you providing these have been selected.

If there is glass in the lite to be split, the correct receptor needs to be chosen.

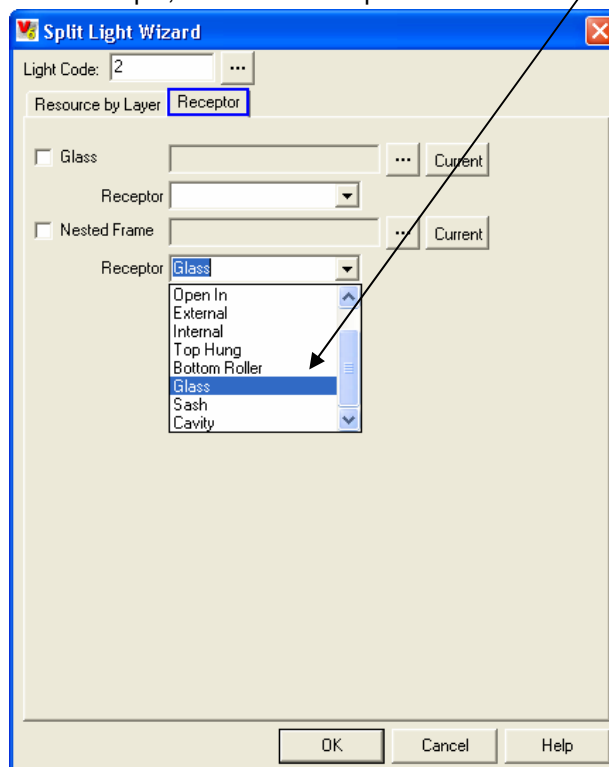

Horizontal Dimension Wizard

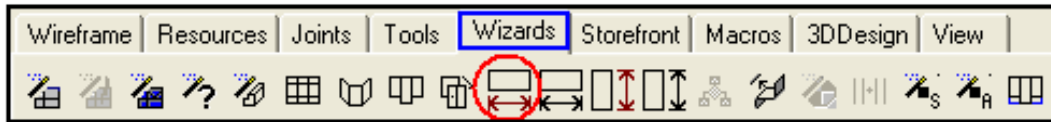

This Wizard allows you to set up a dimension for a Lite. This can be done by the following steps –

- Select the Lite that you want to place a dimension on.
- Click on the Wizards Tab and click on the  button. This will then display the following screen.

- Enter in the Width that you want to set the Dimension to. (Millimetres).
- Select the Line that you would like to move, either Left or Right.
- Type in a Name for the Dimension.
- Select the Left and Right Reference Objects. This will be Day Lite.
- Select whether or not you would like to place a Constraint on the Dimension. Entering in Minimum & Maximum Values. This will then stop the user from going below or above these values.
- Or you are able to specify a Formula.

Vertical Dimension Wizard



This Wizard allows you to set up a dimension for a Lite. This can be done by the following steps –

- Select the Lite that you want to place a dimension on.
- Click on the Wizards Tab and click on the  button. This will then display the following screen.

- Enter in the Height that you want to set the Dimension to. (Millimetres).
- Select the Line that you would like to move, either Top or Bottom.
- Type in a Name for the Dimension.
- Select the Top and Bottom Reference Objects. This will be Day Light.
- Select whether or not you would like to place a Constraint on the Dimension. Entering in Minimum & Maximum Values. This will then stop the user from going below or above these values.
- Or you are able to specify a Formula.

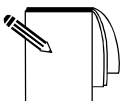

Note: When creating Dimensions it is important not to move your frame from the origin (i.e. the dotted line on your drawing board). Make sure you select the correct line to move so that you frame does not move off this origin point.

Section 6 - Macro Tab

Grid Frame MACRO



The Grid Frame Macro provides the same functions as the Grid Frame Wizard that we looked at earlier on the Wizards tab.

Door MACRO

LIDCO have created a series of Door Macros within their relevant frames to automate this process and ensure no steps are 'missed' by operators.

These can be accessed via the Macro Tab –

There is a choice of Hinged and Sliding doors in either Pocket Glazed or Bead Glazed options.



Instructions for use of these Macros is explained in the Design Trainer Manual – Pages 11 & 12

Fixed Lite MACRO



This Macro places a fixed lite in any selected frame.

Eg: You can use this macro to change a door back to a fixed lite in 1 easy step.

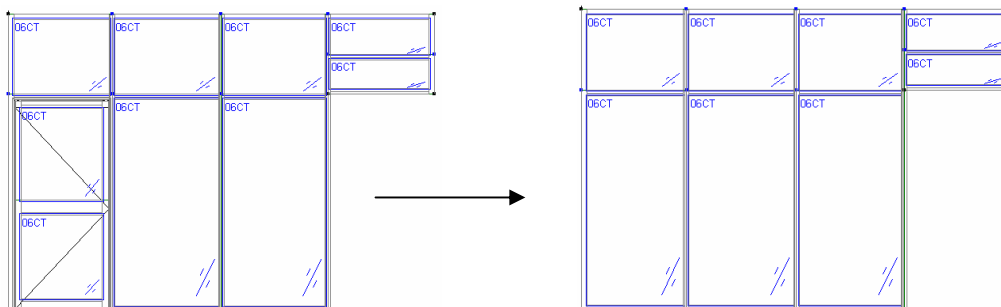

Awning Window MACRO



Insert an Awning Window into your frame by following these steps-

- Select the lite that you want to use by clicking it so it turns Red
- Click on the Awning Window Macro icon
- Select your window options

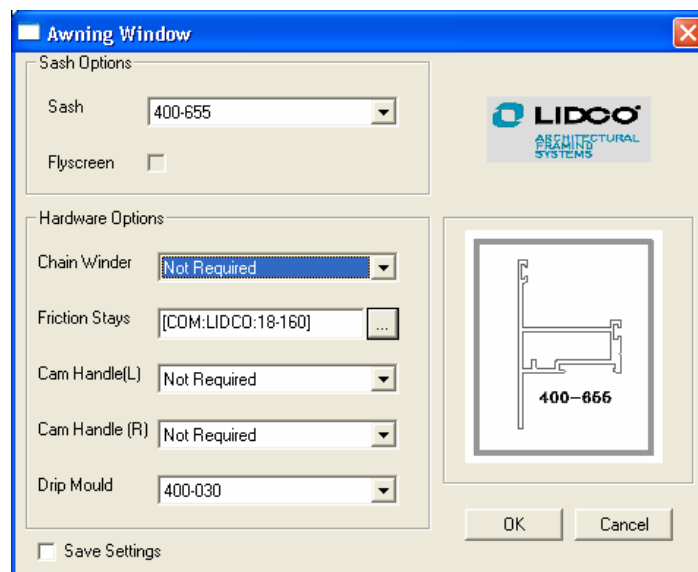

- Click OK one you have finished to place the awning window into the frame

Raked Frame MACRO

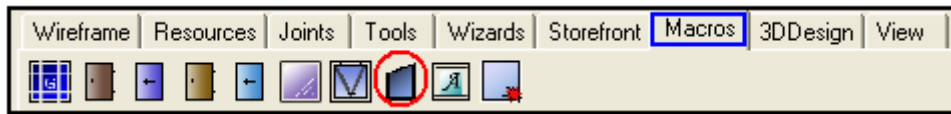

This Macro is designed to lead the estimator through the necessary steps to rake a frame on the Drawing Board.

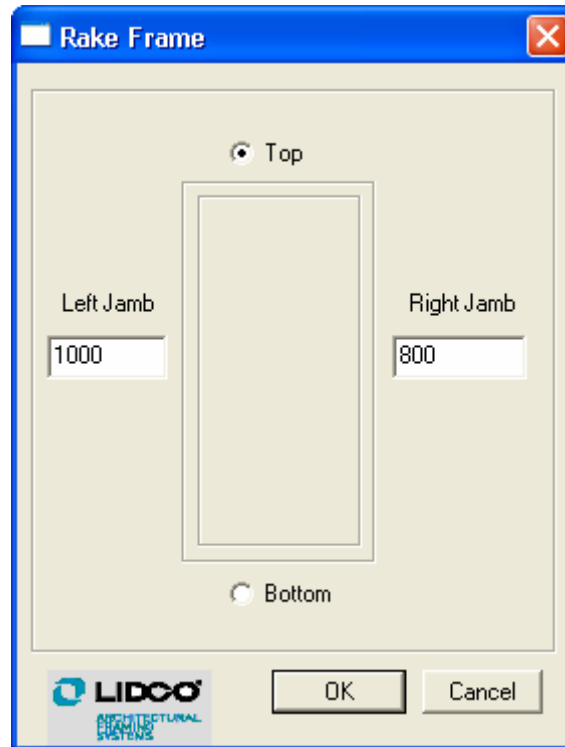

Select which end of the Frame you want to move either Top or Bottom.
Change either the Value of the Left Jamb or the Right Jamb.

E.g. Enter Move Top and Right Jamb 800 as in the above example

The result-

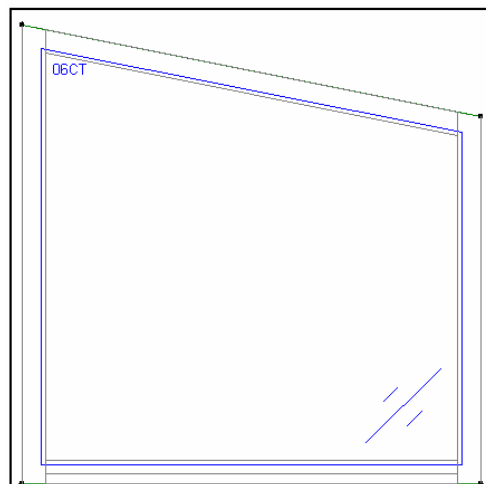

Angle Trim MACRO



This Macro is designed to attach angle trim to various parts of the frame in 1 easy step.

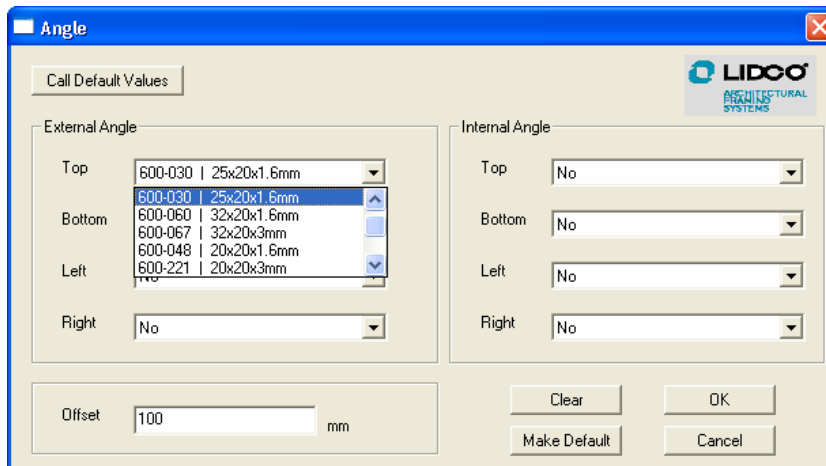

- Select the placement & type of angle trim required from the drop-down menus.
- Enter the offset
- Click OK to populate the frame

Lite by Lite Glazing MACRO

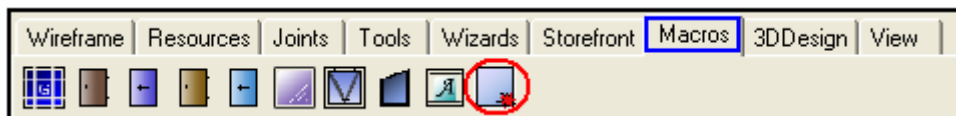

When selected, this Macro will display the current frame with BLUE edges around each lite containing glass. The glass selected within each lite at this stage will depend on the selection made in DEFAULTS.

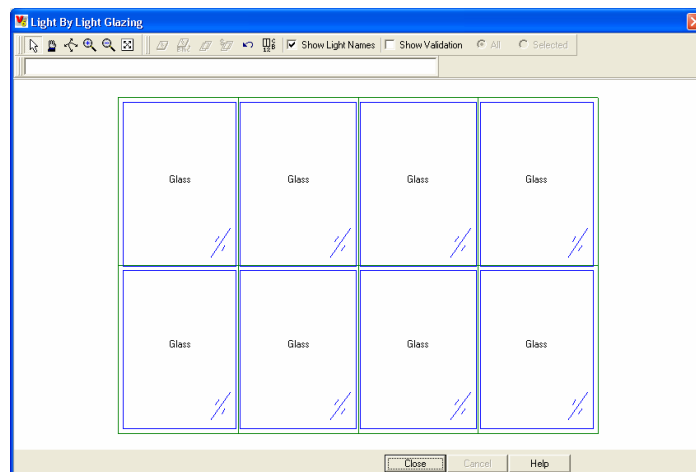

To change a glass selection, simply click on the lite (or multiple lites by holding down the SHIFT key) to be changed and select the Glass icon

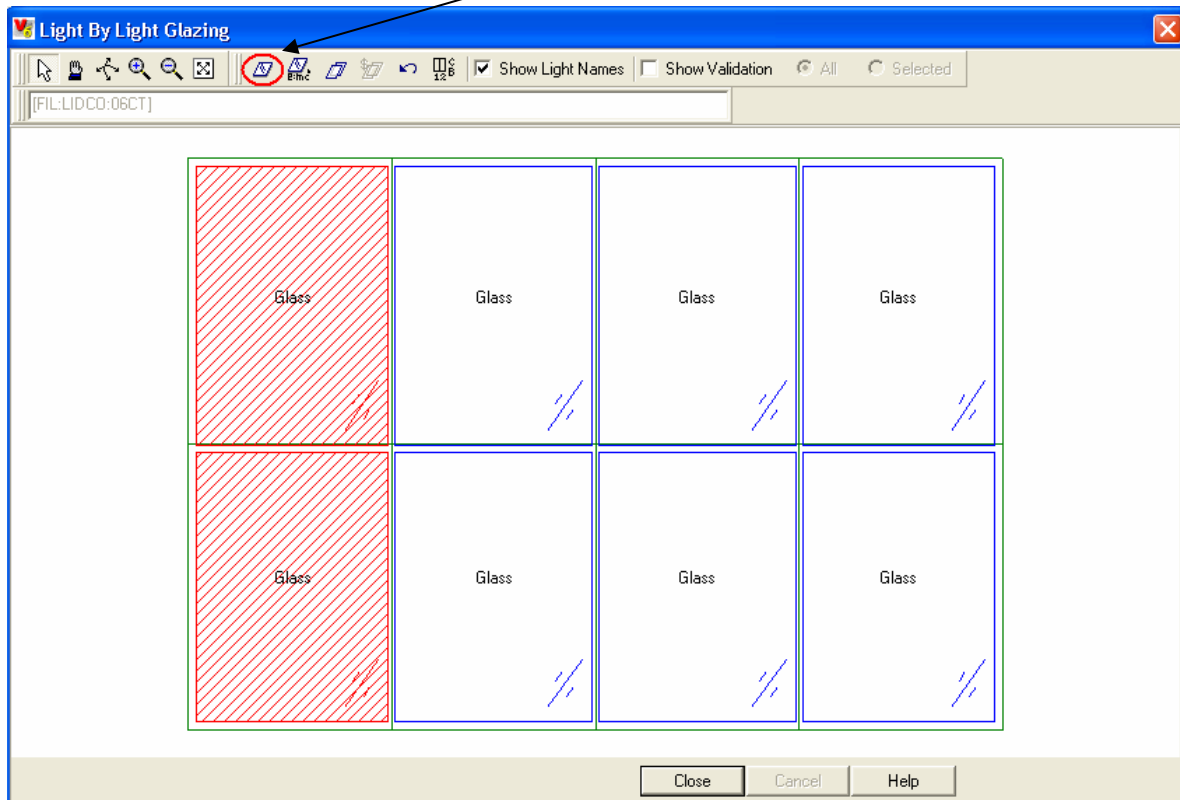

This will take you to the Glass browser where you can select the appropriate glass type.

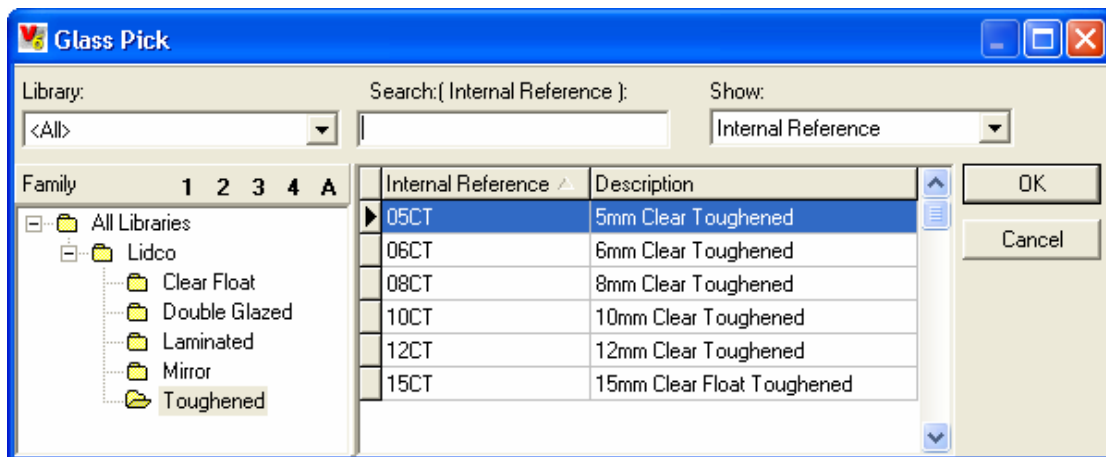

Once you have selected your glass, click OK.

Sliding Window Macro



- Select the lite to insert the window into by clicking it so it turns Red.

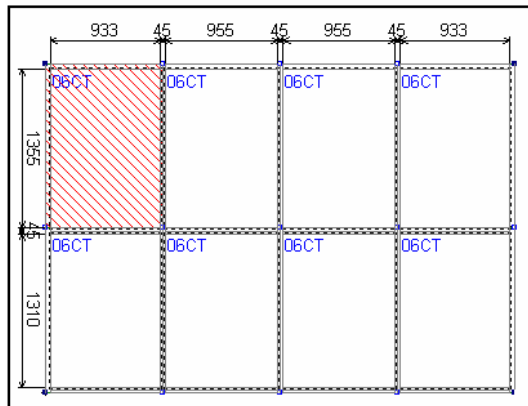

- Click on the Sliding Window Macro icon
- Select Track, Configuration & Latch options, then click OK to populate the frame.

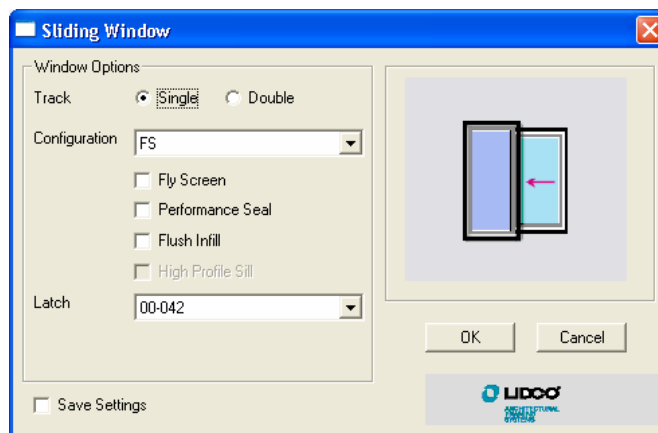

Double Hung Window Macro



- Select the lite to insert the window into by clicking it so it turns Red.

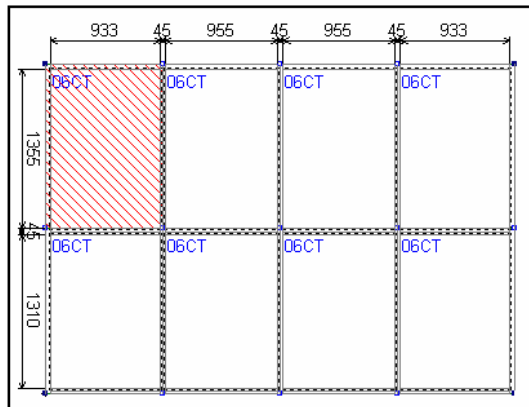

- Click on the Double-hung Window Macro icon
- Select Flyscreen option & click OK to populate the frame



Sub Head / Sub Sill Macro



- Select the lite to insert the sub head or sill into by clicking it so it turns Red.

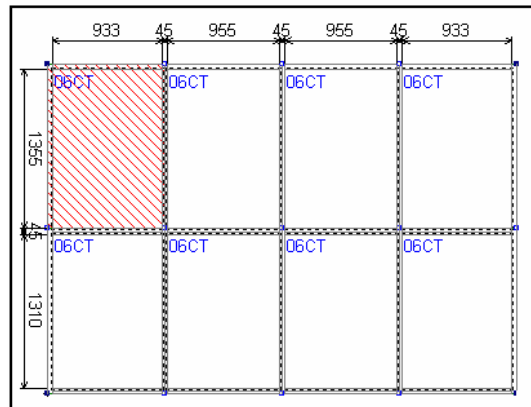

- Click on the Sub Head/Sill Macro icon
- Select placement options & click OK to populate the frame

